

# GENERAL CATALOGUE

					
<b>PIPE CUTTING MACHINE</b>	<b>ROTARY PIPE CUTTER</b>	<b>HYDRAULIC PIPE BENDER</b>	<b>CHAIN CLAMP</b>	<b>SMALL DIAMETER CLAMP</b>	<b>WELDING ELECTRODE OVEN</b>
					
<b>FULL BODY SAFETY HARNESS</b>	<b>SHOCK ABSORBER DOUBLE LANYARD SCAFFOLDING WITH HOOK</b>	<b>FALL ARRESTER</b>	<b>RESCUE TRIPOD</b>	<b>CHAIN BLOCK</b>	<b>LEVER HOIST</b>
					
<b>WIRE ROPE PULLING HOIST</b>	<b>ELECTRIC WIRE ROPE HOIST</b>	<b>WIRE ROPE SLING</b>	<b>CHAIN SLINGS</b>	<b>CARGO LASHING</b>	<b>POLYESTER WEBBING SLING</b>
					
<b>HAND HYDRAULIC PALLET TRUCK</b>	<b>POWER STACKER BATTERY OPERATED</b>	<b>MOVEABLE STEEL GANTRY CRANE</b>	<b>BRANO MECHANICAL JACK</b>	<b>SKATES FOR HEAVY LOAD</b>	<b>VERTICAL &amp; HORIZONTAL PLATE LIFTING CLAMP</b>
					
<b>UNIVERSAL SPILL ABSORBENT GRANULES</b>	<b>OIL SPILL KIT</b>	<b>OIL SPILL CONTAINMENT PRODUCTS</b>	<b>RUST REMOVER</b>	<b>INDUSTRIAL CLEANER &amp; DEGREASER</b>	<b>HEALTH CARE PRODUCTS</b>

# MATERIAL HANDLING EQUIPMENTS

**MT** TOP SELLER  
EXCELLENT SERVICE



**MT** LONG SERIES  
PALLET TRUCK



**MTB** WITH HAND BRAKE



Hand Pallet Truck				
Item/Type		MT25	MT30	MT50
Capacity Q	Kg	2500	3000	5000
Min. Fork Height h	mm	85   75	85	85
Max. Fork Height h1	mm	200   190	200	195
Fork Length	mm	1150	1150	1150
Width overall Forks B	mm	540/685	540	550

Super Long or Wide Pallet Truck				
Item/Type		MTLE20	MTL20	MTL35
Capacity Q	Kg	2000		3500
Min. Fork Height h	mm	75/85		85
Max. Fork Height h1	mm	190/200		200
Fork Length	mm	1100/1150/1220	1500/1800/2000	1500/1800/2000
Width overall forks	mm	838/850/1000	540/685	540/685

Hand Pallet Truck				
Item/Type		MTB25		
Capacity Q	Kg	2500		
Min. Fork Height h	mm	85	75	
Max. Fork Height h1	mm	200	190	
Fork Length	mm	1150		
Width overall forks	mm	540		



Low Profile Pallet Truck (51mm/35mm)			
Item/Type		MT-Low 51mm	MT-Super Low
Capacity Q	Kg	1500	1000
Min. Fork Height h	mm	51	35
Max. Fork Height h1	mm	165	90
Fork Length	mm	1150	1120
Width overall Forks B	mm	540	530



4 - Way Pallet Truck			
Item/Type		MT2W	
Capacity Q	Kg	1500	
Min. Fork Height h	mm	85	
Max. Fork Height h1	mm	85-170-210	
Fork Length	mm	1150	
Width overall Forks B	mm	540	



Galvanized Pallet Truck			
Item/Type		MTG	
Capacity Q	Kg	2000	
Min. Fork Height h	mm	85	
Max. Fork Height h1	mm	200	
Fork Length	mm	1150	
Width overall Forks B	mm	540	



Stainless Pallet Truck		
Item/Type		MTSS-304
Capacity Q	Kg	2000
Min. Fork Height h	mm	85
Max. Fork Height h1	mm	200
Fork Length	mm	1150
Width overall Forks B	mm	540



Stainless Pallet Truck			
Item/Type		MTSS316	
Capacity Q	Kg	2000	
Lifting Height h	mm	200	
Fork Width	mm	540	
Fork Length	mm	1150	
Net Weight	Kg	82	



Economic Pallet Truck With Scale			
Item/Type		MTE20	
Capacity Q	Kg	2000	
Min. Fork Height h	mm	85	
Max. Fork Height h1	mm	200	
Fork Length	mm	1150	
Width Overall Forks B5	mm	540	
Battery	V	DC 1.5Vx2	

**MT HD** PALLET TRUCK WITH SCALE



H/D Pallet Truck With Scale		
Item/Type		MTPS20
Capacity Q	Kg	2000
Min. Fork Height H1	mm	85
Max. Fork Height H2	mm	200
Fork Length (A)	mm	1150
Width Overall Forks B	mm	555

**MTT**  
Rough Terrain Truck



Rough Terrain Truck		
Item/Type		MTT12
Capacity Q	Kg	1200
Max. Fork Height H Max.	mm	233
Min. Fork Height H Min.	mm	63
Overall Size LxWxH	mm	1375 x 1605 x 1200
Net Weight	Kg	225

**MTS** ELECTRIC



Electric Scissor Lift Pallet Truck		
Item/Type		MTS
Capacity Q	Kg	1000
Min. Fork Height H	mm	85
Max. Fork Height H1	mm	800
Fork Length l	mm	1170
Width Overall Fork b5	mm	540/685
Battery	V/Ah	0.8KW

**MTHL**



Scissor Pallet Truck		
Item/Type		MTHL
Capacity Q	Kg	1500
Min. Fork Height H	mm	85
Max. Fork Height H1	mm	800
Fork Length l	mm	1100
Width Overall Fork b5	mm	520/680

**MT series**

Lifting Lowering Transport

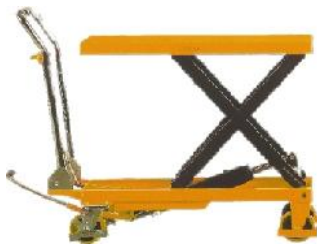

Table Truck				
Item/Type		MT50	MT75	MT100
Capacity Q	Kg	500	750	1000
Min. Table Height h13	mm	285/340	420	380
Max. Table Height h1	mm	880	990	990
Dimension of Table	mm	815x500/850x500	1000x510x55	1016x510x55
N.W.	Kg	81	125	140

**MTD**

High Lift Table Truck with Double Scissor Action



Table Truck		
Item/Type		MTD70
Capacity Q	Kg	700
Min. Table Height h13	mm	445
Max. Table Height h1	mm	1500
Dimension of Table	mm	1220 x 610
N.W.	Kg	195

**MTETT**



Electric Table Truck		
Item/Type		MTE20
Capacity Q	Kg	2000
Lowered Height c	mm	190
Raised Height h	mm	1010
Lifting Speed With Load	mm/s	22
N.W.	Kg	280

**MTL series**



Platform Stacker		
Item/Type		MT415
Capacity Q	Kg	400
Max. Height H1	mm	1500
Min. Platform Height	mm	85
Platform Width	mm	576
Weight	mm	91

**MT-LIGHT**  
MINI DOUBLE USE STACKER



Hand Stacker		
Item/Type		MT220
Capacity Q	Kg	220
Min. Fork Height H	mm	50
Max. Fork Height H1	mm	1250
Fork Length l	mm	750
Fork Width B5	mm	1100

**MT-H**



MTH Series		
Item/Type		MTH1030
Capacity Q	Kg	1000
Lowerd Fork Height	mm	80
Max. Fork Height	mm	3000
Fork Length	mm	900
Overall Width	mm	800

**MT-H**



Hand Stacker			
Item/Type		MTH15	MTH10
Capacity Q	Kg	1500	1000
Min. Fork Height h 13	mm	85	85
Max. Fork Height h3	mm	1600	2500
Fork Length L	mm	900/1150	900/1150
Width Overall Forks B5	mm	330-740/550	330-740/550



**MT15**



Electric Pallet Truck		
Item/Type		MT15
Capacity Q	Kg	1500
Lift Height H3	mm	115
Fork Height Lowered H13	mm	85
Overall Length	mm	1645
Width Overall Forks B1	mm	540

**MT - MMT22AC**



Electric Pallet Truck		
Item/Type		MT - MMT22AC
Capacity Q	Kg	2200
Lift Height H3	mm	120
Fork Height Lowered H13	mm	85
Overall Length	mm	1815/1885
Overall Width b1	mm	726

**MTMAXAC**



Electric Pallet Truck		
Item/Type		MTMAXAC
Capacity Q	Kg	2700
Lift Height H3	mm	120
Fork Height Lowered H13	mm	83
Overall Length	mm	1770/1840
Width Overall Forks B1	mm	726

**MTS 1030-W**



Straddle Type Semi-Electric Stacker		
Item/Type		MTM1030W
Capacity Q	Kg	1000
Lift Height h3	mm	3000
Fork Height Lowered H13	mm	700
Overall Length	mm	1800
Fork Dimensions	mm	35/100/1150

**MTM15**



Semi - Electric Stacker		
Item/Type		MTM1535
Load Capacity Q	Kg	1500
Lift Height h3	mm	3500
Fork Height Lowered H13	mm	85
Length to face of fork L2	mm	610/670
Width Overall B1	mm	777

**MTE15** SERIES



Electric Stacker			
Item/Type		MT1536M	MT1546M
Capacity Q	Ton	1.5	1.5
Lift Height H3	mm	3515	4550
Lowered height H13	mm	50	50
Overall Length	mm	2064	1920
Width Overall b1	mm	795	915

**MTR13**



Reach Stacker		
Item/Type		MTR1345
Capacity Q	Kg	1300
Lift Height H3	mm	4450
Lowered height H13	mm	50
Overall Length	mm	2400
Width Overall b1	mm	1104

**MT15T**



Electric Stacker			
Item/Type		MT1550T	MT1555T
Capacity Q	Kg	1500	1500
Lift Height h3	mm	4915	5415
Lowered Height H13	mm	85	85
Overall Length	mm	2170	2170
Width Overall B1	mm	1040	1040

**MT2036**



Electric Stacker		
Item/Type		MT2036
Capacity Q	Kg	2000
Lift Height h3	mm	3600
Lowered Height H13	mm	85
Overall Length	mm	2170
Width Overall B1	mm	1040



**MT MOBILE SCISSOR LIFT ACCESS PLATFORM**



Mobile Scissor Lift Access Platform		
Item/Type		MTMSL 45-14
Load Capacity	Kg	450
Min. Height	mm	2000
Max. Height	mm	14000
Lifting Power	Kw	3Kw
Total Weight	Kg	2400Kg

**MT MOBILE AERIAL WORK PLATFORM**

**SINGLE MAST TYPE**



Mobile Aerial Work Platform	
Item/Type	MTAWP10-100
Lft. Capacity	276lbs / 125 kg
Working Height	38ft4.68m / 11.7m
Overall widthl	2ft 9.46in / 0.85m
Lifting Power	0.75kw
Total Weight	772lbs / 350 kg

**MT MOBILE AERIAL WORK PLATFORM**

**DUAL MAST TYPE**



Mobile Aerial Work Platform	
Item/Type	MTAWP12-200
Lft. Capacity	441lbs / 200kg
Working Height	44ft 11.36 in / 13.7m
Overall widthl	3ft 1.40in / 0.95m
Lifting Power	1.1kw
Total Weight	1433lbs / 650kg

**MT DRUM TILTER**



Drum Tilter		
Item/Type		MT36
Capacity	Kg	364
Drum Height	mm	915.5
Litre	L	210
Size Diameter		572
Net Weightl	Kg	50

**MT35**



Stacker Type Drum Tilter		
Item/Type		MT35
Rated Capacity	Kg	350
Lifting Height	mm	1425
Overall Length	mm	1190
Overall Width	mm	890
Net Weightl	Kg	155



**ROMOLD LTD**<sup>®</sup>  
specialist manufacturers of polyethylene products



**BT30**  
Drum Trolley  
1x205 ltr



**PDDH**  
Poly Drum Trolley  
with handle  
for 30ltr container

**Drum Clamp**

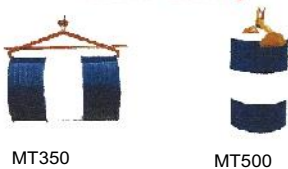

MT350

MT500



**DT**  
Drum transporter



**MT-600**

**Drum puller**

MODEL		MT350	MT500
Capacity Q	Kg	350	500
Net Weight	Kg	6	9
Drum	liter	210	210
Mode		DT30	DT55
Capacity kg	kg	320	410
Drum Size	gallon	30	55
Inside Diameter	mm	500	603
Plastic Swivel castors Dia.x Width	mm	76x30	76x30
Net Weight	kg	3.6	5
Minimum Qty	purchase	50	5C

**Drum Lifter**



Capacity (t)	Chain Size (mm)	Length of lift chain (mm)	Net weight (kg)
1000	6x18	500	3.6

**Drum Clamp**

Model	Capacity (kg)	Jaw opening(mm)	Weight (kg)
<b>MT-600</b>	600	0.30	5

## Cargo Trolley | Load Skate

CE



Model	Cap (t)	Roller q'ty (pcs)
AS20	2	2 nylon or PU
AS40	4	4 nylon or PU
AS60	6	6 nylon or PU
AS120	12	8 nylon or PU
SS40	4	4 nylon or PU
SS60	6	8 nylon or PU
SS240	24	16 nylon or PU
MTP-3	2	3 PU
MTP-5	4	5 PU
6000-06	6	6 nylon or PU
MT-4	1.5	4 Steel

Model	Cap (t)	Roller q'ty (pcs)
MTO-4	6	4 PU
MTO-6	8	6 PU
MTO-8	12	8 PU
MTO-9	15	9 PU
MTO-12	18	12 PU
MTA-4	6	4 PU
MTA-6	8	6 PU
MTA-8	12	8 PU
MTA-9	15	9 PU
MTA-12	18	12 PU
MTQ-4	6	4 PU
MTQ-6	8	6 PU
MTQ-8	12	8 PU



### Combined type

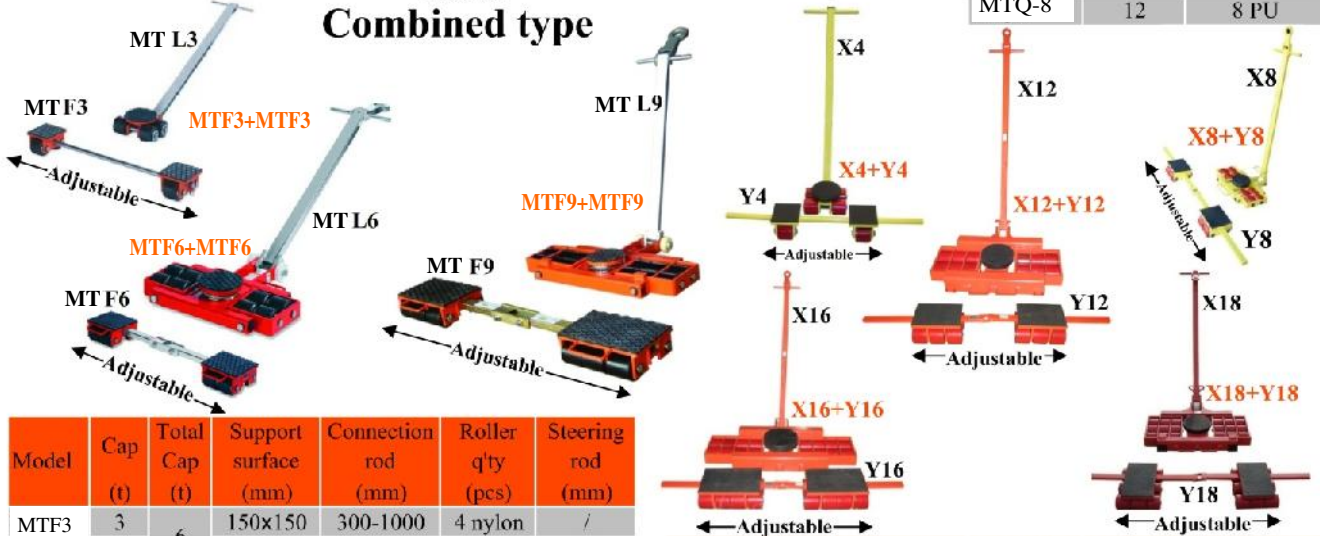

Model	Cap (t)	Total Cap (t)	Support surface (mm)	Connection rod (mm)	Roller q'ty (pcs)	Steering rod (mm)
MTF3	3	6	150x150	300-1000	4 nylon	/
MTL3	3	6	Ø170	/	4 nylon	950
MTF6	6	12	200x200	640-1030	8 nylon	/
MTL6	6	12	Ø170	/	8 nylon	1080
MTF9	9	18	320x200	840-1230	12 nylon	/
MTL9	9	18	Ø170	/	12 nylon	1080
MTF12	12	24	200x407	1104-1430	16 nylon	/
MTL12	12	24	Ø170	/	16 nylon	1080
MTF18	18	36	200x407	1014-1430	16 nylon	/
MTL18	18	36	Ø170	/	16 nylon	1080
MTF20	20	40	280x220	440-1600	8 steel	/
MTL20	20	40	Ø250	/	8 steel	1620
MTF30	30	60	288x300	650-1830	12 steel	/
MTL30	30	60	Ø250	/	12 steel	1620
MTF40	40	80	370x370	820-1760	16 steel	/
MTL40	40	80	Ø250	/	16 steel	1620
MTF60	60	120	390x440	1100-2730	24 steel	/
MTL60	60	120	Ø250	/	24 steel	1620

Model	Cap (t)	Total capacity (t)	Support surface (mm)	Roller quantity (pcs)	Connection rod (mm)
X4	4	8	Ø150	4	800
Y4	4	8	140x120	4	300-1000
X8	8	16	Ø160	8	1100
X8	8	16	200x160	8	400-1300
X12	12	24	Ø180	12	1100
Y12	12	24	220x180	12	400-1400
X16	16	32	Ø200	16	1100
Y16	16	32	240x200	16	400-1500
X18	18	36	Ø200	18	1500
Y18	18	36	280x200	18	400-1500
X24	24	48	Ø220	24	1500
Y24	24	48	350x200	24	400-1600
X32	32	64	Ø240	32	1500
Y32	32	64	440x220	32	500-2000



# LIFTING EQUIPMENTS

## Chain Hoist | Chain Block

CE



### Features

- » Robust light weight steel construction is resistant to external shocks.
- » Lower headroom allows more available space.
- » High-accuracy and high tenacity spur gear, small dimension but nice performance.
- » Ultra strong, wear-resisting and heat treated Grade T8 alloy steel chain as standard load chain.
- » Surface treatment: electrostatic powder coating for protection against rust and corrosion.
- » Safety factor(minimum breaking load): 4 times of the rated capacity.
- » Each piece of chain hoist is operationally tested to 150% of the rated capacity and issued with an individual Certificate of Conformity.
- » Double-pawl and double guide rollers enhance performance, safety and reliability:  
In case one pawl spring is broken or damaged, the other one maintains functions. This mechanism makes safety and durability redoubled.
- » High strength 360 degree rotating top and bottom hooks equipped with safety latches:  
Drop-forged top and bottom hooks are with sufficient strength and tenacity. In case of overload, it will be deformed without breaking. Besides, the design of hook abdomen is enhanced, to make hanging easier, also the safety latch can prevent hanging tool from slipping out.
- » Unique bearing design for high efficiency:  
High quality bearing to make its mechanical efficiency improved significantly, smallest hand-pull force brings about maximum work efficiency.
- » Load chain guide mechanism:  
Excellent load chain guide mechanism to make load chain fed smoothly.  
The chain guide sprocket is strong and durable.
- » Comply with the latest Machinery Directive and relevant EN safety standards.

Capacity (ton)	Standard Lift (m)	Load Chain (mm)	NO. of Load Chain Falls	Chain Pull to Lift Full Load (N)
0.5	3	6x18	1	231
1	3	6x18	1	309
1.5	3	7.1x21	1	320
2	3	8x24	1	320
3	3	7.1x21	2	360
5	3	9x27	2	414
7.5	3	10x30	3	420
10	3	10x30	4	420
20	3	10x30	8	420x2
30	3	10x30	12	450x2

## Lever Hoist | Lever Block

### Features

- » High-strength, stamped steel construction for external resistance and longer service life.
- » Light hand-pull, easy for lifting.
- » Optimized design makes routine inspection and maintenance easily.
- » Ultra strong, wear-resisting and heat treated Grade T8 alloy steel chain as standard load chain.
- » Surface treatment: electrostatic powder coating for protection against rust and corrosion.
- » Reliable load actuated brake with non-asbestos brake discs.
- » Chain guides provide smooth chain operation.
- » 360 degree rotating top and bottom hooks equipped with safety latches.
- » 360 degree handle rotation with short stroke to ratchet loads.
- » Unique bearing design for high working efficiency.
- » Safety factor(minimum breaking load): 4 times of the rated capacity.
- » Each piece of lever hoist is operationally tested to 150% of the rated capacity and issued with an individual Certificate of Conformity.
- » Comply with the latest Machinery Directive and relevant EN safety standards.

Capacity (ton)	Standard Lift (m)	Load Chain (mm)	NO. of Load Chain Falls	Chain Pull to Lift Full Load (N)
0.75	1.5	6x18	1	140
1	1.5	6x18	1	140
1.5	1.5	7.1x21	1	220
2	1.5	8x24	1	240
3	1.5	10x30	1	320
6	1.5	10x30	2	340
9	1.5	10x30	3	360





## Non-Sparking Chain Block



Model/Type:  
**EX-CB**

### Feature

- » Perfect alternative for non-sparking applications in potentially explosive environments.
- » Widly used in many fields, like oil platform, chemical plant, refinery, pipeline construction, off-shore energy, mine, shipyard,...., etc.
- » Manufactured as per EX CII Grade and relevant safety standards.
- » Safe, high efficiency and reliable in operation with minimum maintenance.
- » Can be combined to use with non-sparking geared trolley.



Model / Type	EX-CB-0.5	EX-CB-1	EX-CB-1.5	EX-CB-2	EX-CB-3	EX-CB-5	EX-CB-10	EX-CB-20
Rated capacity (ton)	0.5	1	1.5	2	3	5	10	20
Standard lifting height (m)	2.5	2.5	2.5	3	3	3	3	3
Test load (ton)	0.63	1.25	2	2.5	4	6.3	12.5	25
Headroom Hmin (mm)	255	306	368	444	486	616	700	1000
Chainpull to lift full load (N)	211	304	343	314	343	383	392	392
Chain falls	1	1	1	2	2	2	4	8
Diameter of load chain (mm)	6	6	8	6	8	10	10	10
Net weight (kg)	8	10	16	14	24	36	68	156
Extra weight per meter of extra lift (kg)	1.7	1.7	2.3	2.5	3.7	5.3	9.7	19.4

\*Longer chain is available, maximum length: up to 12 meters.\*

More non-sparking tools are available.

- Non-sparking lever block (from 0.7ton to 9ton)
- Non-sparking geared trolley (from 0.5ton to 30ton)



## Air Chain Hoist | Pneumatic Chain Hoist

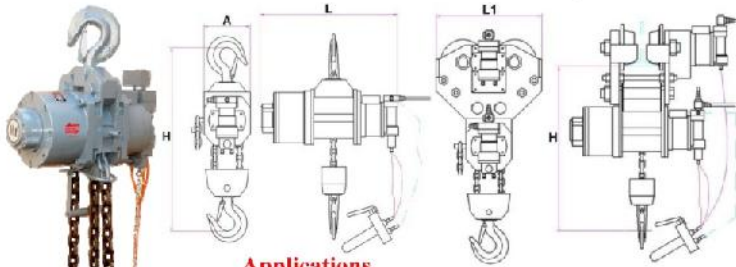

### Features

- » Air motor vane is imported and with 0% water-solubility, superstrong stability and abrasion resistance.
- » Apply to complex and dangerous working places or environment with limited space.
- » Small, light and simple for operation.
- » Longer working time and low maintenance .
- » Clean, safe, to prevents fire accident, electricity attacks and no break-ups.
- » Equipped with air trolley is available.

### Applications

- » Professional production automation line.
- » Marine, aircraft production & maintenance.
- » Petroleum, chemical industry, chemical fibre, printing & dyeing.
- » Harsh working environments like inflammable, explosive, dust, poisonous, high temperature, paint-spray industry.

### Fitted with

- » Overload protection device.
- » Emergency stop function.
- » Air shut-off valve on air inlet.
- » Exhaust muffler.
- » Upper and lower limit switches.

10t



100t

Model	0.125	0.25	0.5	1	2AK	2AL	2	3AK	3AL	3K	3L
Capacity (t)	0.125	0.25	0.5	1	2	2	2	3	3	3	3
Lifting speed (m/min)	(full load)	24	18	9	5	2	2.6	3.5	1.3	2	1.4
	(empty load)	28	29	18	12	3	3.5	7	7.5	3.5	2
Descending speed (m/min)	(full load)	30	30	15	10	4	4.5	6	4	4.5	2
	(empty load)	20	18	12	7	3	3	4	3	3	1.7
Trolley speed(if equipped)		20	18	15		12				10	
Load chain dia. (mm)		5x15	6x18	7x21		10x30	7x21	10x30		8x24	
No. of load chain falls				1			2	1		2	
Beam width(if with trolley)		16-28b			20a-32c						
Air motor power (kw)	(hoist)	0.6	0.8	1	1.4	1.2	1.5	1.3			
	(trolley)			0.3			0.4	0.5			
Air consumption (m <sup>3</sup> /min)	(hoist)	0.8		1.2	1.5	1.4	1.8	1.6			
	(trolley)			0.7			0.8	0.9			
Air pressure (Mpa)					≥0.6						
Noise (db)	(hoist)	68-72			72-75		68				
	(trolley)			65							
Inside dia. of air source tube (mm)		12			16						
Working system		100%									
Dimension (mm)	H	320	380	390	790	400	820	550			
	L	285	370	380	415	380	415	380			
	L1			310				360			
	A	122	140	140	180	140	180	150			

Model	5L	6K	6L	10	12	16	20	30	50	80	100
Capacity (t)	5	6	6	10	12	16	20	30	50	80	100
Lifting speed (m/min)	(full load)	1.2	0.7	1	1.2	1.1	0.85	0.65	0.4	0.3	0.2
	(empty load)	2	1.5	2	2.4	1.5	1.6	0.85	0.7	0.6	0.5
Descending speed (m/min)	(full load)	2	1.6	2	2.5	1.4	1.6	1	0.65		
	(empty load)	1.6	1.2	1.6	2	1.2	1	0.65	0.55		
Trolley speed(if equipped)		8		7		6		5	4	3	
Load chain dia. (mm)		10x30	13x39	14x42	16x48	18x54		22x66	26x78		
No. of load chain falls		2			2			4	6		
Beam width(if with trolley)		25a-63c		28a-63c		36a-63c		56a-63c		63c	
Air motor power (kw)	(hoist)	1.5		3.5			4.5		5.5	5.8	
	(trolley)	0.5		0.7			1.2		1.5	2.8	
Air consumption (m <sup>3</sup> /min)	(hoist)	1.9		4			5.3		6.8	7.8	
	(trolley)	0.9		1.3			1.8		2.8	5.5	
Air pressure (Mpa)					≥0.6						
Noise (db)	(hoist)	72-75		75		77		80	82		
	(trolley)	68		72		75			78		
Inside dia. of air source tube (mm)		16			22			38			
Working system		100%									
Dimension (mm)	H	840		1050	1190	1280	1480	1690	1890	2820	
	L	415		570		590	830	990	1185	1540	
	L1	360			500		660		690	700	
	A	180		235	245		300	370	415	480	



20t



## Battery Chain Hoist



Move It-Holland battery chain hoist is an ideal tool for use in the areas without power supply, like forest, farm, wilderness, under-construction buildings, plumbing, ....etc. Also suitable for safety and rescuing applications.

### Characteristics

- » Lightweight and easy to carry.
- » Compact, fine appearance and user-friendly and robust.
- » No mains power required at the work site.

### Specifications

1. Rated capacity: 500kg
2. Lifting speed: 2.2m/min
3. Load chain: 4.0x12mm x 4mtr(Grade 80), longer length available.
4. Power system: DC 24V rechargeable Li-ion battery
5. Battery performance: 20-25min (continuously use with full loading)
6. Safety device: Overloading protector.
7. Overloading warning alarm: Buzzer sounds while overloading occurs.
8. LED loading display: Green - full; yellow - medium; red - weak.
9. Hoist weight / Gross weight: 9.4kg / 17.7kg

### Features for hoist

- » Hooks: Alloy steel material by die-casting formation, wide opening with safety latch.
- » Housing: Aluminum alloy shell, light and compact.
- » Motor: High-speed brush motor (series wound) with high-efficiency.
- » Quick Connector: Industrial 2-Pin power connector, easy connection and storage for control switch.
- » Load chain: Alloy steel load chain (4.0mm, grade 80 standard) provides a higher resistance against fatigue, wear and rust.
- » Brake / Clutch: Friction clutch can make the motor idle running to avoid damage under overload and over tight revolving.
- » Gears: High efficiency driving system plus 3-stage planetary speed reducing gear and 2-stage spur speed reducing gear.
- » Chain Container: One-piece HDPE chain container provides higher resistance, tensile and durability.

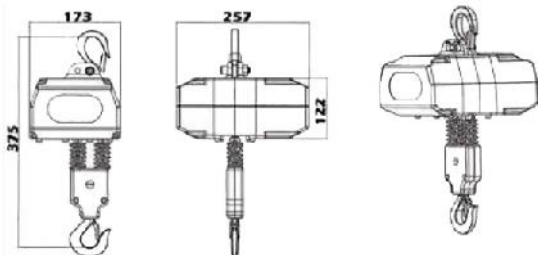

**Accessories included**

1. Battery chain hoist c/w chain(4.0mm x 4mtr) x 1.
2. Top hook assembly x 1.
3. Bottom hook assembly x 1.
4. HDPE chain container x 1
5. Trigger switch set x 1, consisting of:  
Trigger: stepless variable speed.  
Reverse switch: left: forward rotation of drum; right: rearward rotation of drum.  
Control cord: 3-meter-long flexible PVC cord.  
Quick connector: easy plug in & out.  
Battery condition indicator: LED display to monitor battery consumption.  
Overload warning buzzer for top safety.
6. High-performance rechargeable Li-ion battery(DC 24V 4.0Ah) x 2:  
Battery performance: 20-25 min. (continuously use with full loading).
7. 220V/50Hz/1Phase charger & adaptor x 1.
8. Portable blow case x 1
9. Operation manual x 1
10. Color box x 1



# ELECTRIC CHAIN HOIST

## 500 Kg - 5 Ton



### Single Speed

### Technical Parameters

Model	MT Series				
	MTS 0.5 T	MTS 1 T	MTS 2 T	MTS 3 T	MTS 5 T
Capacity(t)	0.5	1	2	3	5
Lifting Model	Single speed	Single speed	Single speed	Single speed	Single speed
Lifting Speed(m/min)	8.3	6.3	6.9	6.6	3.3
Motor Power(Kw)	0.9	1.5	3.0	3.0	3.0
Rotation Speed(r/min)	1440				
Insulation Grade	F				
Power Supply	220V-690V				
Control Voltage	24V/36/48V				
No of Chain	1	1	1	1	2
Spec. Of Load Chain	Ø6.3	Ø7.1	Ø10.0	Ø11.2	Ø11.2

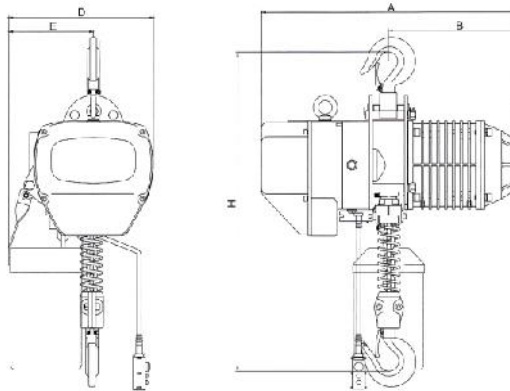

### ELECTRIC CHAIN HOIST HOOK TYPE DIMENSIONS

Model	H	A	B	D	E
MTS 0.5 T	530	460	230	230	170
MTS 1 T	630	520	260	230	170
MTS 2 T	800	615	295	230	265
MTS 3 T	930	617	295	230	265
MTS 5 T	1030	670	313	430	325

# ELECTRIC CHAIN HOIST

## 500 Kg - 5 Ton



### Dual Speed

### Technical Parameters

Model	MT Series				
	MTD 0.5 T	MTD 1 T	MTD 2 T	MTD 3 T	MTD 5 T
Capacity(t)	0.5	1	2	3	5
Lifting Model	Dual speed	Dual speed	Dual speed	Dual speed	Dual speed
Lifting Speed(m/min)	7.2/2.4	6.9/2.3	6.9/2.3	5.4/1.8	2.7/0.9
Motor Power(Kw)	0.8/0.27	1.8/0.6	3.0/1.0	3.0/1.0	3.0/1.0
Rotation Speed(r/min)	2880/960				
Insulation Grade	F				
Power Supply	3 Phase 380V 50HZ				
Control Voltage	24V/36/48V				
No of Chain	1	1	1	1	2
Spec. Of Load Chain	Ø6.3	Ø7.1	Ø10.0	Ø11.2	Ø11.2

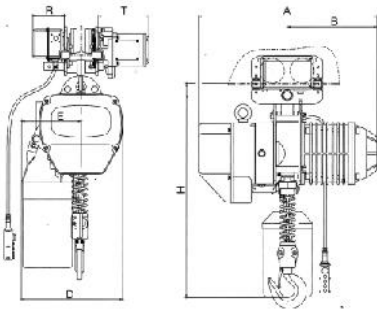

### ELECTRIC CHAIN HOIST WITH TROLLEY DIMENSIONS

Model	H	A	B	D	E
MTD 0.5 T	635	460	230	230	170
MTD 1 T	650	520	260	230	170
MTD 2 T	770	615	295	230	265
MTD 3 T	830	617	295	230	265
MTD 5 T	1015	670	313	430	325



## Electric Trolley

### Technical Parameters

Capacity(t)	Unit(mm)				Speed(m/min)	Motor(Kw)	Minimum radius turn
	W	U	R	T			
0.5	315	212	142	321	21m/min or 11m/min	0.4	0.8
1	315	212	142	231		0.4	0.8
2	325	220	142	231		0.4	0.9
3	340	250	142	231		0.75	1.0
5	400	291	142	231		0.75	1.5
7.5	400	291	142	231		0.75	1.8
10	500	371	142	231		0.75	2.0



# ELECTRIC CHAIN HOIST

## 10 Ton

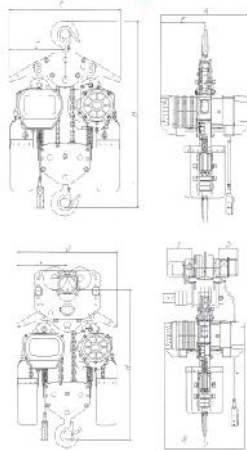

### Technical Parameters

Model	10 T(S)	10 T(D)
Capacity (t)	10t	10t
Lifting Speed (m/min)	2.7	2.7/0.9
Motor Power (Kw)	3.0x2	3.0x2/1.0x2
Rotation Speed (r/min)	1440	2880/960
Insulation Grade	F	F
Power Supply	3Phase 380V 50HZ	3Phase 380V 50HZ
Control Voltage	24V 36V 48V	24V 36V 48V
No. of Chain	4	4
Spec. of Load Chain	Φ11.2	Φ11.2
Net Weight (Kg)	300	300/ 380

### Hoist with Hook

### Size specification

Model	H	A	B	D	E
10 T(S)	1400	630	315	890	445
10 T(D)	1400	670	388	890	445

### Hoist with Electric Trolley

### Size specification

Model	H	A	B	D	E
10 T(S)	1190	630	315	890	445
10 T(D)	1190	670	388	890	445

## 15 Ton



### HOIST WITH ELECTRIC TROLLEY

### Size specification

Model	15 T (S)	15 T (D)
Capacity (t)	15t	15t
Lifting Speed (m/min)	1.8	1.8/0.6
Motor Power (Kw)	3.0x2	3.0x2/1.0x2
Rotation Speed (r/min)	1440	2880/960
Insulation Grade	F	F
Power Supply	3Phase 380V 50HZ	3Phase 380V 50HZ
Control Voltage	24V 36V 48V	24V 36V 48V
No. of Chain	6	6
Spec. of Load Chain	Φ1.2	11.2
Net Weight (Kg)	382	455

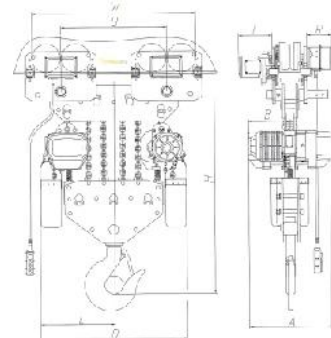

### Size specification

Model	H	A	B	D	E	W	U	R	T
15 T(S)	1310	630	315	1070	535	926	560	142	231
15 T(D)	1310	670	388	1070	535	926	560	142	231



## Push Trolley



These hand-operated manual trolleys are divided into two types: push trolley and geared trolley.

Push trolley is operated by pushing the load lifted, geared trolley by pulling the hand chain. Both of these items are running on the bottom of I-beam and can be also attached with hoist to become a conveyor system.

### Features

- » Compact design and easy assembly.
- » Can be installed or removed at any point along the track, also additional uses with hoist or other lifting tools to improve efficiency and labor-saving.
- » Adjustable to suit H and I beam flanges with various widths.
- » Drop-forged steel wheels for strong and lower wear.
- » Built-in lugs prevent falling and act as bumper guards.
- » Ball surface wheel designed to establish centered contact with beams for running along universal tracks, and for distributing load away from beam flanges to reduce flange stress.
- » Used on straight or curved track.
- » Fitting for special beam widths is available.
- » As per Machinery Directive 2006/42/EC and standard EN 13157+A1:2009.



Model:  
MT<sub>1</sub>

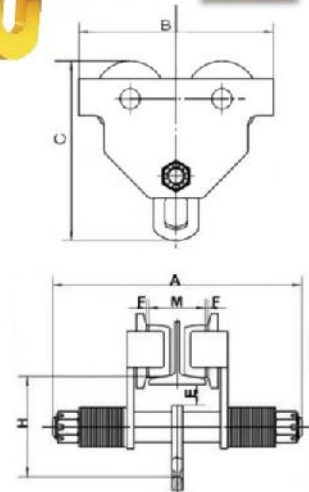

Model	MT <sub>1</sub>						
Rated capacity(T)	0.5	1	2	3	5	10	
Test load (kN)	7.35	14.71	29.42	44.13	61.29	122.58	
Min radius of curve (m)	0.9	1	1.1	1.3	1.4	1.7	
Dimension (mm)	A	264	335	353	371	393	436
	B	216	260	300	345	390	470
	C	195	239	286	336	393	500
	E	31	32.5	31	35	37	45
	F	≈3					
I-Beam width (mm)	64-152	64-203	88-203	102-203	114-203	125-203	

## Geared Trolley



Model:  
MT<sub>2</sub>

- » Longer hand chain is available.

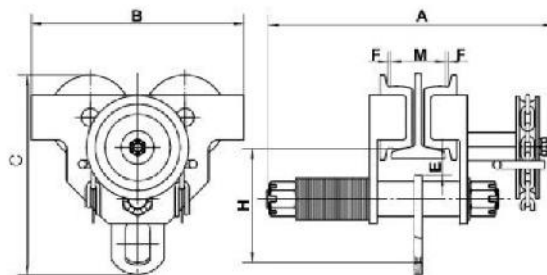

Model	MT <sub>2</sub>						
Rated capacity	0.5T	1T	2T	3T	5T	10T	
Test load (kN)	7.35	14.71	29.42	44.13	61.29	122.58	
Running height (m)	2.5	2.5	3	3	3	3	
Min radius of curve (m)	0.9	1	1.1	1.3	1.4	1.7	
Dimension (mm)	A	264	390	400	430	444	489
	B	216	260	300	345	390	470
	C	195	239	286	336	393	500
	E	31	32.5	31	35	37	45
	F	≈3					
	H	110	136	161	185	220	280
	K	/	/	/	/	/	/
	L	/	/	/	/	/	/
I-Beam width (mm)	50-102	64-203	88-203	102-203	114-203	125-203	

## Heavy-Duty Snatch Block with Shackle (single-sheave)

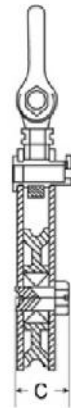
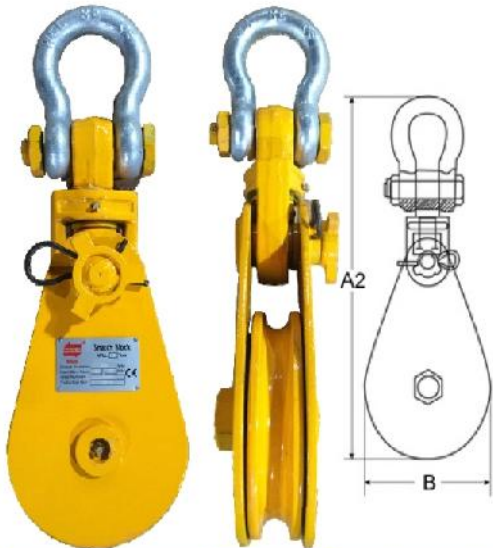

### Feature

- » Solid all-steel construction, heavy-duty type design.
- » Easy opening mechanism ensures a fast change of wire rope while block is suspended.
- » Fully machined sheave.
- » Sheave has a sealed ball bearing system, fully lubricated for maintenance-free operation.
- » Forged steel eye is designed to avoid twisting of unit during operation.
- » Fitted with grease nipples for ease of maintenance
- » Special design of side plates restricts rope from jamming.
- » Move It snatch blocks are operationally tested to 2 times of the Working Load Limit(WLL) and come with an individual test certificate.
- » Each unit is supplied complete with high strength safety bow shackle to European standard.
- » All Move It snatch blocks have an individual serial number stamped on the identification plate.
- » As per the latest Machinery Directive and EN safety standards.

Model	WLL (ton)	Sheave Q'ty (pcs)	Sheave Diameter (mm)	A2 (mm)	B (mm)	C (mm)	for Wire Diameter (mm)	Net Weight (kg)
MT-3"x1	2	1	75	286	82	70	7-9	3.8
MT-4 1/2"x1	4	1	115	345	120	70	10-12	6.2
MT-6"x1	4	1	150	399	160	70	16-18	8.3
MT-6"x1	8	1	150	475	160	93	20-22	14.1
MT-8"x1	8	1	200	528	210	93	20-22	18.7
MT-8"x1	15	1	200	663	210	102	22-24	33
MT-10"x1	10	1	250	679	260	115	24-26	34.7
MT-10"x1	12	1	250	679	260	115	24-26	34.7
MT-12"x1	12	1	300	767	310	133	24-26	54
MT-12"x1	15	1	300	788	310	133	26-28	55
MT-14"x1	22	1	355	952	365	140	28-32	109
MT-16"x1	22	1	400	1019	415	140	28-32	118
MT-16"x1	30	1	400	1126	415	155	32-35	164
MT-20"x1	30	1	500	1256	514	162	32-35	208
MT-24"x1	50	1	600	1525	625	240	46-50	418

## Snatch Block with Hook (single-sheave)



### Features

- » Durable powder coat finish.
- » Hook type is fitted with safety latch.
- » Fully machined sheave.
- » Heavy-duty permits to perform under extreme condition.
- » Forged spare parts enhance the quality.
- » 2~10 sheaves for bigger capacity available(max. up to 320ton).

Model	WLL (ton)	Sheave Q'ty (pcs)	Sheave Diameter (mm)	for Wire Diameter (mm)
MT-1H	1	1	106	7.7-11
MT-2H	2	1	142	11-14
MT-3.2H	3.2	1	166	12.5-15.5
MT-5H	5	1	202	15.5-18.5
MT-8H	8	1	264	20-23
MT-10H	10	1	300	23-24.5
MT-16H	16	1	390	28-31
MT-20H	20	1	436	31-35

# SNATCH BLOCK



## SNATCH BLOCK MODEL: HPB Capacity: 0.5-6.4T

**Snatch Block**, hinged, with single steel sheave Capacity 500-6400 kg . One side of the snatch block is hinged and can be opened for easily and quickly positioning of the wire rope on the sheave. It can also provide a quick and versatile rigging point or redirect a wire rope.

### Features:

- Swinging the hook in the direction of pull securely locks the snatch block.
- The high quality cast steel sheaves have machined grooves.
- When choosing and classifying snatch blocks, take the principles for Rope Drives DIN 15020 into consideration.

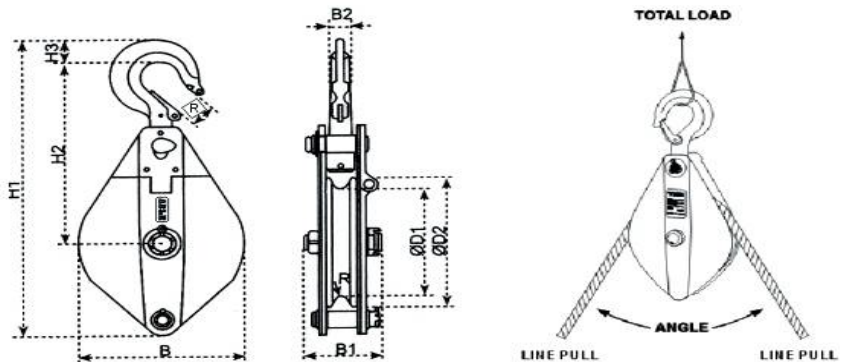

### ANGLE FACTOR MULTIPLIERS

Angle	Factor	Angle	Factor
0°	2.00	100°	1.29
10°	1.99	110°	1.15
20°	1.97	120°	1.00
30°	1.93	130°	0.84
40°	1.87	145°	1.76
45°	1.84	140°	0.68
50°	1.81	150°	0.52
60°	1.73	160°	0.35
70°	1.64	170°	0.17
80°	1.53	180°	0.00
90°	1.41	/	/

### TECHNICAL PARAMETERS

Item Code	Model	Working Load (T)	Hook latch H (mm)	Rope Dia. (Mm)	B	B1	B2	H1	H2	H3	D1	D2	D3	Weight (kg)
221005	HPB05	0.5	20	Φ5	95	62	16	260	190	20	75	88	3	2
221010	HPB10	1	23	Φ7	118	76	17	305	200	23	85	105	4	3.2
221020	HPB20	2	27	Φ13	119	92	24	425	263	30	150	190	7	7.3
221032	HPB32	3.2	31	Φ15	230	108	28	496	295	40	180	220	9	13.1
221064	HPB64	6.4	42	Φ15	270	116	35	655	375	47	210	260	10	22.1



# Permanent Magnetic Lifter

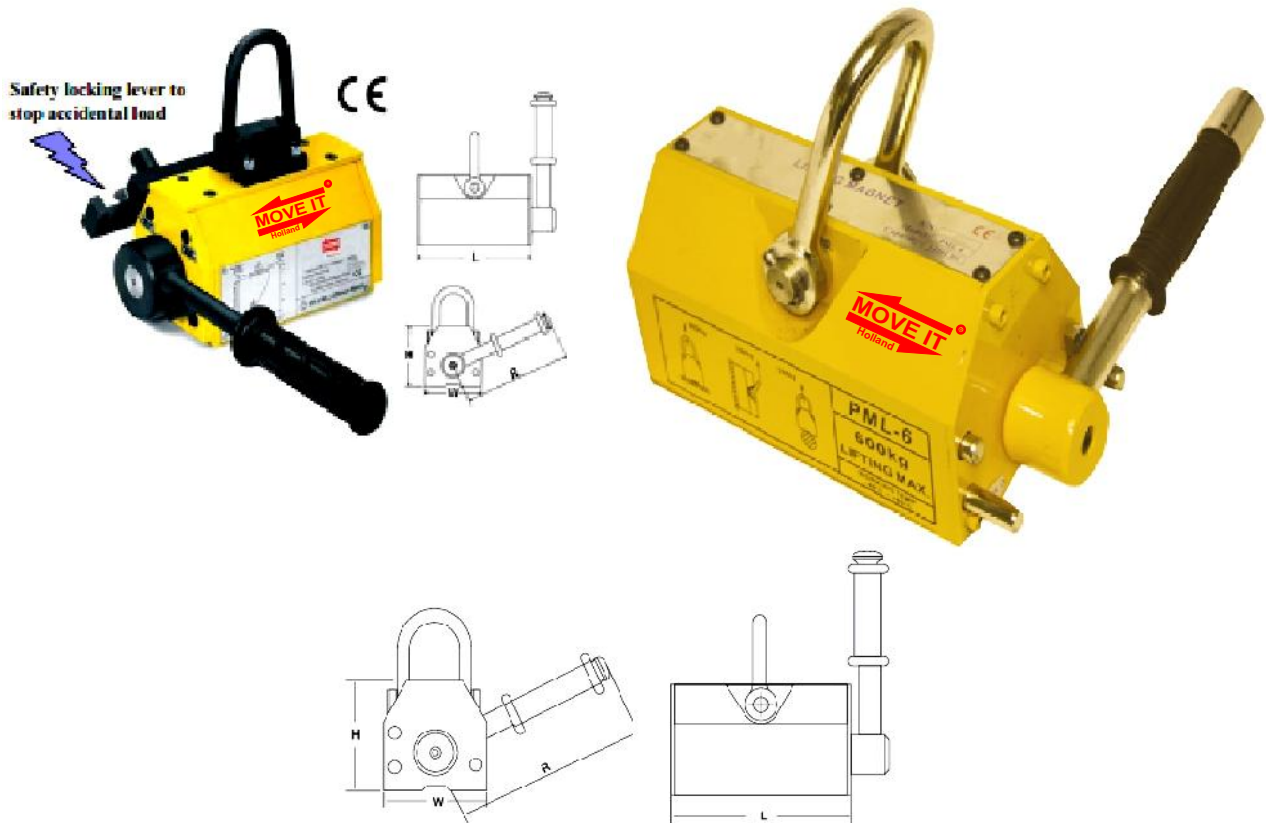

Model	Rated lifting strength (Kgf) (Flat)	Cylindrical Lifting Strength (Kgf) (Round)	Max pull-off strength (kgf)	W	L	H	R	Dead Weight KG
MTL/ PML-B	100	50	300	69	122	185	160	6
	300	100	900	95	192	225	250	10
	600	200	1800	122	232	120	220	30
	1000	300	3000	154	332	320	450	60
	2000	600	6000	196	392	420	450	130
	3000	1000	9000	220	447	453	600	207
	5000	2500	1500	260	640	645	600	320
	6000	2000	0	296	720	266	710	398

Reduction of capacity	% of capacity
Temperature $\leq 60^{\circ}\text{C}$	100%
Humidity $\leq 80\%$	100%
St 52	95%
Alloy steel	80%
High carbon steel	70%
Cast Iron	45%
Nickle	45%
Austenitic, Stainless steel	0%
Brass	0%
Aluminum	0%



# Crane Scale



## General type: MTC-S



### Feature

- » High-quality alloy steel load receptor.
- » Aluminum die-casting enclosure.
- » High-duty bow shackle.
- » High-duty eye hook.
- » High capacity rechargeable battery.
- » Infrared remote controller.

### Function

- » Zero.
- » Low voltage alarm.
- » Overload alarm/record.
- » 3-point linearity correction.
- » Gravity acceleration value set.

- » Tare in/out.
- » Battery supervision
- » Digital calibration.
- » kg/lb switchable.

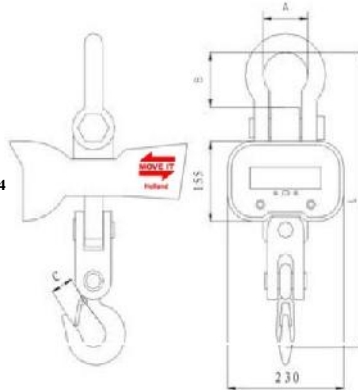

### Specification

Accuracy Class	OIML III
Tare Range	100% F.S.
Zero Range	4% F.S.
Safe Overload	120% F.S.
Ultimate Overload	400% F.S.
Overload Alarm	100% F.S.+9e
Battery	6V/10Ah
Battery life	>100 hour
Adaptor	9V/1500mA
Temperature Range	-10°C to +40°C
Remote Distance	≥10m

Model	Max. cap (kg)	Min. cap (kg)	Division (kg)	Resolution (n)	A (mm)	B (mm)	C (mm)	L (mm)
MTC-S	1000	10	0.5	2000	58	83	30	420
	2000	20	1	2000	58	83	30	420
	3000	20	1	3000	73	107	33	480
	5000	40	2	2500	92	135	45	585
	10000	100	5	2000	94	145	60	770
	15000	100	5	3000	128	178	75	860
	20000	200	10	2000	135	250	75	950

	MTC-S1	MTC-S2	MTC-S3	MTC-S4
Metal button	✓	✓		
Touch button			✓	✓
Brightness select	✓		✓	
30mm LCD display		✓		✓
30mm LED	✓			
38mm LED			✓	

## Compact type: MTCS-B, 1t~5t



## Portable type: MTCS-M



## Enhanced type: MTCS-C, 1t~5t (2-battery)



Model	Max. cap (kg)	Min. cap (kg)	Division (kg)	Resolution (n)
MTCS-M	50	0.4	0.02	2500
	100	1	0.05	2000
	200	2	0.1	2000
	300	2	0.1	3000
	500	4	0.2	2500
	1000	10	0.5	3000

Mini type	Heat-proof type	Heavy type	Wireless type	Smart type	Economical type	Integrated type	Solid type
<p>MTCS-L 30kg~300kg</p>	<p>MTCS-G1 MTCS-G2 1t~15t 5t~30t</p>	<p>MTCS-Z 10t~50t</p>	<p>MTCS-F 1t~50t</p>	<p>MTCS-S 0.1~1t</p>	<p>MTCS-T MTCS-X Cap.: 1t ~ 5t</p>	<p>MTCS-Y 3t ~ 20t</p>	<p>MTCS-K Cap.: 10t</p>

# Electric Wire Rope Hoist

Technical Data	MT500		MT1000	
	Standard Version	Version with double load cap.	Standard Version	Version with double load cap.
Load Capacity	250 kg	500 kg	500 kg	1000 kg
Lifting Height	12 m	6 m	20 m	10 m
Lifting Speed	10m/min	5m/min	8m/min	4m/min
Cable length	12 m		20 m	
Cable diameter	4.5 mm		6.0 mm	
Resister Cable	≥1600kg		≥3000kg	
Service	S3 20% - 10 min		S3 20% - 10 min	
Mains Voltage	230V~50Hz		230V~50Hz	
Motor performance	P1 1200 w		P1 1800 w	



# Electric Wire Rope Hoist with Trolley

Technical Data	MTWT-1000
Lift Weight (kg)	500/1000
Lift height (m)	20/10
Lift Speed (m/min)	8/4
Hoist Power (W)	1800
Trolley Power (W)	540
Power Supply	230V/50Hz
Trolley Speed m/min	13
Least Radii (m)	1.5
Recommend l steel Width (mm)	80-102
Wire rope dia (mm)	6.0
Weight of machine	54



# SAFE LIFT<sup>®</sup>

## ELECTRIC WIRE ROPE HOIST

Main Performance and Technical Specifications

**MICRO ELECTRIC  
ROPE HOIST  
500KG / 1000KG**



Model: SL-1000			
Load Capacity	500/1000kg	Lifting Speed	510m/min
Voltage	220V~50Hz	Rating Current	10A
Insulating Grade	B	Work Level	M 1
Protecting Grade	IP54	Input Power	2000W
Capacitance	70VF/450V	Work rate	S3-20% 10min
Wire Rope	Ø 6.0mm	Machine NW	30.65kg
Lifting Height	20/10m		



# WIRE ROPE HOIST

- Single Grid Low Headroom Wire rope Hoist
- Double Grid Wire Rope Hoist



**MOVE IT** Wire Rope Hoist are designed and built for today's heavy-duty wire rope hoist applications. Euro-style design features and construction make our **MOVE IT** wire rope hoist extremely durable, high reliable and very low maintenance for years of trouble free service.

**MOVE IT** adopt advanced and mature technologies and expertise for this line of wire-rope hoist achieve exceptional performance with unparalleled safety and durability

## Features

Capacity Range : 1t - 100t

Compact design for space saving

Euro-style Module technology

High duty motor increase your productivity

Overload limiter and limit switches are standard for safety

Dual speed as standard

High quality components integrated



## Compact structure, light weight but with strength, precise positioning to improve the work efficiency

MOVE IT wire rope hoist adopt European design, the mechanical structure is compact and strong but with light weight and small size. For single grid type hoist, low headroom is the standard feature, which means can cover large room and height on working site. For double grid type hoist, the wheel pressure us small and can be customized by different grider span. our wire rope hoist wit dual speed as standard on lifting & traveling compared with single speed hoist, it will bring good performance on positioning, and will improve the working efficiency absolutely.

## Modular design and multiple options can meet various demands of customer

MOVE IT concept of modular design has always been throughout the whole product design, which ensures the standard and interchangeability of parts, greatly reduces the maintenance costs of products. All products series of MOVE IT provided with complete set of spare parts, and professional service team ensure to provide after-sales service to solve the problems from customers in time.

## High quality mechanical & electronic components can ensure good working performance

MOVE IT select every component seriously, no matter to the mechanical parts like motors, brakes, and steel wire rope, or the electronics as inverter, contactors, and relay. High quality components are always the basic rule for every good products. We believe that only the good quality components integrated together, can ensure the good working performance as complete machine.



### Low operation cost, green energy and environment friendly

MOVE IT wire rope hoist with same design crane can significantly reduce self-weight of complete system, and decrease the total power consumption which almost save 30% power every year on average compared with other domestic products. Meanwhile, the running noise is lower than national standard which can create a quite and comfort working environment.

### Safe and reliable, running monitoring and simple and convenient maintenance

MOVE IT technology product is provided with various functions such monitoring, protection, which can ensure safe and reliable operation of the crane, and its running monitoring unit can make detailed records of running condition of electric hoist, running status of motor and safety working cycle, and provide warning in advance. All records can provide data for maintenance, and the root of problem should be understood to be provide maintenance much more timely and efficiently.

### High Production Efficiency Improved by Precise positioning

MOVE IT wire rope hoist with double lifting speed as standard configuration and transition speed control of trolley ensure the efficient running of crane in workshop, and ensure the plans of customer can be implemented as schedule. By the frequency conversion technology, it can reduce waving of loads, which makes the positioning more quickly and accurately. Meanwhile it can reduce the impact on whole machine when start or breaking, more smooth and safe when operation.



## MODULAR DESIGN FLEXIBLE COMBINATION



#### Trolley Drive Unit

Trinity of high performance motor, Reduction gearbox and Crane.  
Compact structure, excellent performance.  
Low energy consumption, low noise and eco-friendly design.  
Variable frequency control, smooth running, low impact and meeting requirements of a variety of speed.  
Asbestos-free brake disc and its normal service life can be up to one million times.  
No-wear design, maintenance-free, long service life.



#### Drum

Use the Q345-type seamless steel tube as raw material and process it by numbers of working procedure.  
Advanced processing methods to ensure concentricity of the drum.  
The depth of rope groove is in compliance with the FEM standard.  
High-strength pressing plates and bolts are fastened on the end of the wire rope to ensure the safety of lifting.



#### Swift Plug & Socket

Aviation plug and socket for swift connection with power and control, Easy operation and less maintenance, safe and durable, with high protection class in Ip55.



#### Lifting Height Limiter

Freely adjustable screw lifting height limited with high precision, wide adjustment range, safe and reliable.  
Multiple-contact configurations can effectively achieve the function of transition with low and high speed and the stop during the rise and fall.



#### Rope Guide

Light weight, good wear resistance, to reduce the wear of wire rope effectively.  
Prevent wire rope from skipping and loosening to off-groove, and safety first.



#### Wire Rope With High-Performance

The imported wire rope of high-performance with tensile strength up to 2160MPa.  
The surface with galvanized processing for corrosion prevention effectively.  
With good flexibility to ensure wear resistance of the wire rope and prolong its service life.



#### Electric Control Box

Rational design convenient maintenance, decreasing running cost.  
Professional and high quality of electric components, safe and reliable.  
Multiple safety protection devices to ensure equipment safe.  
Protection grade IP55.  
Clear identification to easy for trouble removal.



#### Lifting Hook Group

DIN standard of lifting hook with safety clasp and wire rope sheath, ergonomic design.  
Forged by the high-strength material of T grade.  
Accompanied with nondestructive test certification of lifting hook randomly.

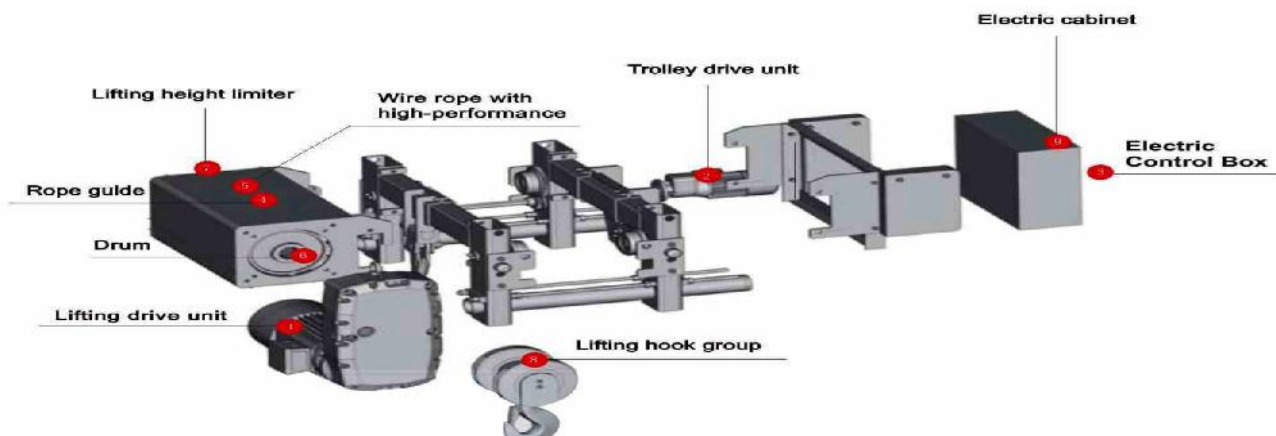



## SINGLE GIRDER WIRE ROPE HOIST

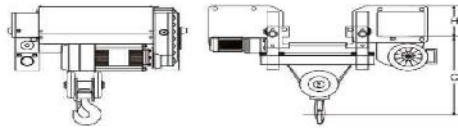

Technical Parameters of SINGLE GIRDER Wire Rope Hoist

Load capacity (Kg)	FEM	ISO	Height (m)	Speed (m/min)	Trolley Speed (m/min)	H Size (mm)	C Size (mm)
1000	4m	M7	6/9/12/18	0.8/5.0	5-20	245	385
1250	3m	M6	6/9/12/18	0.8/5.0	5-20	245	385
1600	3m	M6	6/9/12/18	0.8/5.0	5-20	245	385
1600	4m	M7	6/9/12/18	1.3/8.0	5-20	245	385
2000	2m	M5	6/9/12/18	0.8/5.0	5-20	245	385
2000	3m	M6	6/9/12/18	1.3/8.0	5-20	245	385
2500	3m	M6	6/9/12/18	0.8/5.0	5-20	245	385
2500	3m	M6	6/9/12/18	1.0/6.3	5-20	245	385
2500	2m	M5	6/9/12/18	1.3/8.0	5-20	245	385
3200	2m	M5	6/9/12/18	0.8/5.0	5-20	245	385
3200	2m	M5	6/9/12/18	1.0/6.3	5-20	245	385
5000	2m	M5	6/9/12/18	0.8/5.0	5-20	266	495
5000	2m	M5	6/9/12/18	1.6/10	5-20	296	792
5000	3m	M6	6/9/12/18	1.3/8.0	5-20	296	792
6300	1Am	M4	6/9/12/18	0.8/5.0	5-20	266	495
6300	1Am	M4	6/9/12/18	1.3/8.0	5-20	266	495
6300	2m	M5	6/9/12/18	1.3/8.0	5-20	266	495
6300	3m	M6	6/9/12/18	1.0/6.3	5-20	266	495
8000	1Am	M4	6/9/12/18	1.3/8.0	5-20	296	792
8000	3m	M6	6/9/12/18	0.8/5.0	5-20	296	792
10000	1Am	M4	6/9/12/18	1.0/6.3	5-20	296	792
10000	2m	M5	6/9/12/18	0.8/5.0	5-20	296	792
10000	3m	M6	6/9/12/18	0.66/4.0	5-20	296	792
12500	1Am	M4	6/9/12/18	0.8/5.0	5-20	296	792
12500	2m	M5	6/9/12/18	0.6/4.0	5-20	296	792
12500	2m	M5	6/9/12/18	0.6/4.0	5-20	296	792

## DOUBLE GIRDER WIRE ROPE HOIST

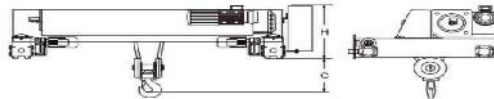

Technical Parameters of DOUBLE GIRDER Wire Rope Hoist

Load capacity (Kg)	FEM	ISO	Height (m)	Speed (m/min)	Trolley Speed (m/min)	H Size (mm)	C Size (mm)
2000	2m	M5	6/9/12/18	0.8/5.0	5-20	230	350
3200	2m	M5	6/9/12/18	0.8/5.0	5-20	230	350
5000	2m	M5	6/9/12/18	0.8/5.0	5-20	230	350
5000	2m	M5	6/9/12/18	0.8/5.0	5-20	230	350
8000	3m	M6	6/9/12/18	0.8/5.0	5-20	540	360
10000	1Am	M4	6/9/12/18	1.0/6.3	5-20	540	360
10000	2m	M5	6/9/12/18	0.8/5.0	5-20	540	360
10000	3m	M6	6/9/12/18	0.66/4.0	5-20	540	360
12500	1Am	M4	6/9/12/18	0.8/5.0	5-20	540	420
12500	1Am	M4	6/9/12/18	1.0/6.3	5-20	540	420
12500	2m	M5	6/9/12/18	0.6/4.0	5-20	540	420
16000	2m	M5	6/9/12/18	0.66/4.0	5-20	640	480
20000	1Am	M4	6/9/12/18	0.66/4.0	5-20	640	480
20000	2m	M5	6/9/12/18	0.53/3.4	5-20	640	480
20000	3m	M6	6/9/12/18	1.0/4.2	5-20	790	620
25000	1Am	M4	6/9/12/18	0.53/3.4	5-20	790	620
25000	2m	M5	6/9/12/18	0.8/3.3	5-20	790	620
25000	2m	M5	6/9/12/18	1.0/4.2	5-20	790	620
32000	2m	M5	6/9/12/18	0.8/3.3	5-20	790	620
32000	2m	M5	6/9/12/18	0-4.9	5-20	895	980
40000	1Am	M4	6/9/12/18	0-4.9	5-20	895	980
50000	2m	M5	6/9/12/18	0-3.2	5-20	895	980
50000	1Am	M4	6/9/12/18	0-4.0	5-20	895	980
63000	1Am	M4	6/9/12/18	0-3.2	5-20	975	1100
63000	2m	M5	6/9/12/18	0-2.4	5-20	975	1100
80000	1Bm	M3	6/9/12/18	0-3.8	5-20	1025	1525
100000	1Bm	M3	6/9/12/18	0-2.1	5-20	1025	1525

## Heavy-Duty Hand Winch

CE



Type: PNW

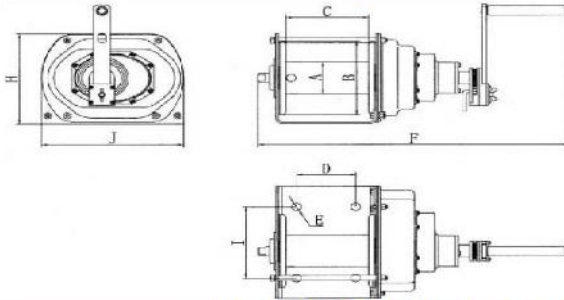

Type/Model	PNW 500	PNW 1000	PNW 2000	PNW 3000	
Rated capacity (ton)	0.5	1	2	3	
Test load (KN)	6.125	12.25	24.5	36.75	
Cable dia. x length (mm x m)	Φ6.3 x 40	Φ8 x 40	Φ9 x 40	Φ12.5 x 40	
Speed ratio	4.33:1	12.19:1	22.68:1	29.16:1	
Max. length of link-pole action (mm)	350	350	350	350	
Min. force of hand turn (N)	120	120	130	180	
Dimension (mm)	A	Φ60	Φ76	Φ90	Φ100
	B	Φ140	Φ175	Φ190	Φ230
	C	150	154	195	205
	D	100	110	155	155
	E	Φ15	Φ18	Φ18	Φ18
	F	403	443	490	549
	H	182	214	230	296
	I	130	170	170	170
	J	245	266	300	365
	Net weight (kg)	14.4	19.7	25.1	44.3

### Feature

- » More convenient, more easy in operation and more widely used.
- » Adopting lever handle, either may shake operation along the whole circle, or may swing operation at any angle in the any position of the circle. It has unique advantage in the narrow space.
- » Seal design prevents foreign matter entering gear box and braking mechanism.
- » The braking material is made of environment material and is more suitable for the special area.
- » Newly-designed brake pawl for better stability of the braking.
- » The handle is adopted free structure to adjust the length freely.
- » The ratchet is big enough to contain more wire rope and more suitable for operating in deep well and remote drawing.

### Application

- » Applied for cross-country vehicle, agriculture, yacht and other special vehicle.
- » It is the device of self-protection and pulling of vehicles and boats, and also may be used for saving in snowfiled, marshland, desert, sea beach, muddy patch and other adverse circumstances.
- » It may be operated for clearing away obstacles, pulling material and installation.
- » It is indispensable safe device of mine, environment protection, forestry, transportation, fire fighting and other open fields.

## Brake Hand Winch

Model	MT25
Capacity Rating LBS (Kg)	2500 (1100)
Gear Ratio	4.1:8L, 10.3:1
Handle Length (mm)	275
Hub Size (mm)	25.4
Drum Storage Mm/m	Φ5x10
Size of Coleres Bele	2x70x8m
Pieces in Each Box	4
Size of Package (CM)	59x47x21

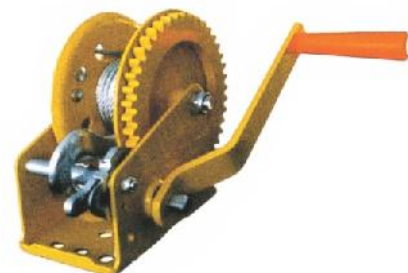



# ECONOMICAL MINI ELECTRIC WINCH

Electric mini winch

**Load: 500 kg x 50m lift**

**Load: 250 kg x 20m lift**

**Model: MTL D 500**

**220 V**

**Model: HXS-250F**

**230 V**

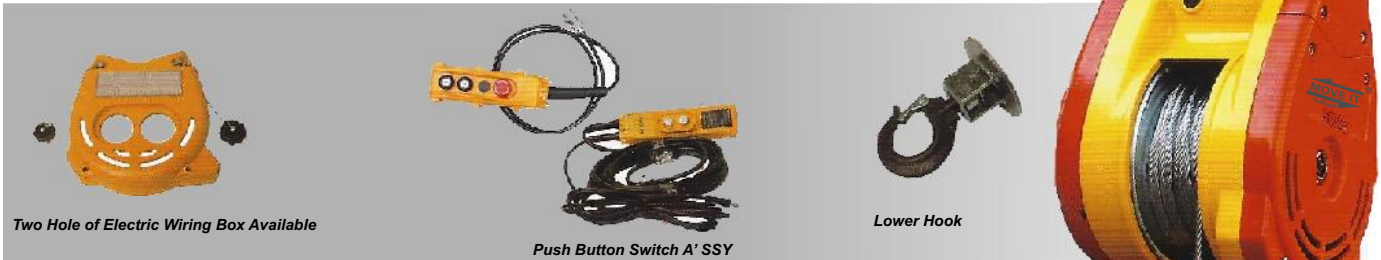

Two Hole of Electric Wiring Box Available

Push Button Switch A' SSY

Lower Hook

## Characteristics :

- The mini hoist can be widely used in hanging for engineering, plants hoist operation, civil hydro power installed piping, Warehousing and shipping the goods; it can be used to lift, raise and, drag. Its compact, lightweight, economy effective, and easy to obtain single-phase power supply
- Using brush less motor series excited of high efficiency industrial grade; there are two selected configurations of single-phase voltage (110 / 220V); its enameled heat levels up to 200 degree, specifically designed for long crane.
- Dual brake system with one mechanical ratchet gear brakes and the other brake resistor short circuit controller; formula oiled copper disc brake with high friction coefficient, which needs no adjustment; immediately brake in power outage or malfunction, great safety and long life.
- Cable stops automatically over the volume limit; cable stops automatically when inverting.
- Direct control which saves tedious lines and has the advantages of easy maintenance, low failure rate, security and stability, control switch with separate power line and quick connector makes it easy to carry.
- Imported steel wire from large manufacturing firms with 3-fold safety factor.
- Use drive bevel reducing gear of high efficiency; heat treatment alloy steel gear with its intensity three times higher than rated hoist.
- Die-casted in one piece, motor body and gearbox have the advantages of strong toughness computer CNC machining high precision low noise, and smooth operation, using automotive-grade powder coating, it has nice appearance; its compacted and light-weighted.

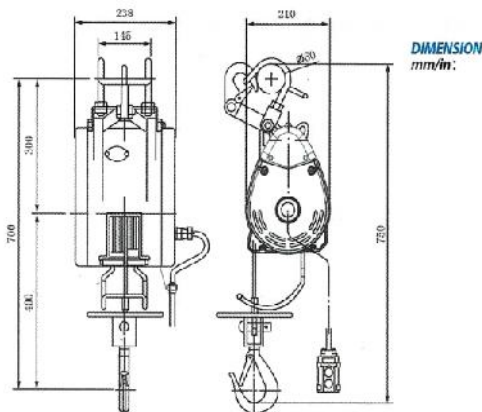

## Technical Parameters:

Model	Capacity (kg)	Power	Phase	Wire rope (mm)	Wire rope lift (mtr.)	Speed (M/min)		Motor (kw)
						50Hz	60Hz	
MTLD 500	500	200-240	1	6	50	12	15	1.8
HXS-250F	250	230V	1	4	20	12	-	1.5

## Specification Parameters:

Model	L (mm)	W (mm)	H (mm)	Package box (mm)			Cu.Ft.	N.W (kgs)	G.W (kgs)
				L	W	H			
MTLD 500	240	210	670	530	270	360	1.45'	20	28
HXS-250F	220	200	630	510	200	310	1.30'	22	30



## Wire Rope Pulling Hoist | Wire Rope Winch



### Feature

- » Lifting capacity ranged from 800kg to 5400kg.
- » Compact, light weight, simple and easy to operate.
- » Versatile and portable unit for pull, lift, drag and stretch applications over long distances.
- » Can be used in horizontal, vertical and angled working positions.
- » Corrosion free aluminium alloy casing.
- » Adjustable telescopic handle for easy operation (0.8t model is fitted with fixed handle.)
- » Backward lever and forward lever placed in tandem can provide a slim design and assure power transfer along the center.
- » Built-in shear pins for overload protection, also can be replaced without removing the load.
- » Equipped with an anchor bolt, offering numerous and versatile connection possibilities with load hooks, sling ropes and sling chains.
- » Rope clamp system easily disengaged with a lever allowing smooth installation of wire rope.
- » Stamped with individual serial number for easy identification and traceability.
- » 20m steel wire rope with eye hook as standard (longer wire rope is available).
- » Parallel clamping system providing evenly distributed grip at a lower force, resulting in less rope wear.
- » Supplied with individual certificate and operation manual.
- » Low operation and maintenance requirements.
- » Conforms to EU Machinery Directive 2006/42/EC and standards EN 13157:2004+A1, AfPS GS 2014:01.



Model: **MT**  
(aluminum casing)

Model		MT 800	MT 1600	MT 3200	MT 5400
Lifting Capacity (kg)		800	1600	3200	5400
Max Travelling Load (kg)		1200	2400	4000	8000
Rated Forward Handpower (N)		343	441	441	745
Rated Forward Travel (mm)		≥52	≥55	≥28	≥30
Rope Diameter (mm)		8.3	11	16	20
Safety Factor for Wire Rope		5	5	5	5
Safety Factor for Static Loading		5	5	5	5
Dimensions	A (mm)	426	545	660	932
	B (mm)	235	280	325	420
	C (mm)	64	97	116	300
	L1 (cm)	-	80	80	88
	L2 (cm)	80	120	120	136

## Lifting Clamp



### Vertical Plate Lifting Clamp

**Features**

- » Heavy-duty industrial plate clamp suitable for lifting and turning various of steel plates.
- » Special alloy steel cam and jaws are drop forged and heat treated for long service life.
- » Equipped with hinged shackle.
- » Antislip design of spring locking device.
- » As per the latest Machinery Directive and relevant EN safety standards.

WLL/Piece (ton)	Jaw Opening (mm)
0.5	0-15
1	0-15
2	0-25
3	0-25
3	0-30
5	0-30
5	0-50
8	0-45
12	0-70
16	60-100
30	80-220



### Horizontal Plate Lifting Clamp

**Features**

- » Suitable for lifting and transporting of steel plates, construction and profiled bar in horizontal position.
- » Alloy steel cam and jaws are drop forged and heat treated.
- » Must be used in pairs.
- » Conforms to the latest Machinery Directive and relevant EN safety standards.

WLL/Pair (ton)	Jaw Opening (mm)
0.5	0-25
1	0-30
2	0-40
3	0-45
4	0-50
5	0-55
6	0-65
6	0-130
8	0-100
10	0-125
16	50-150



### Pipe Lifting Clamp

**Features**

- » Suitable for horizontal lifting and transporting of steel and concrete pipes.
- » Compact shape and relatively low unit weight with a high lifting capacity.
- » The surface is equipped with "special" plastic.
- » Must be used in pairs.
- » Conforms to the latest Machinery Directive and relevant EN safety standards.



WLL/Pair (ton)	Jaw Opening (mm)
1.5	40
3	40
4	50
6	50
8	70
12	70
16	70
18	70

### Girder Clamp | Beam Clamp

**Features**

- » A safe and ideal tool at a fixed position to suspend manual and electric hoists, and overhead loads.
- » Specially designed shape of clamping jaws for distributing load away from beam flange edge to reduce flange stress.
- » Also used for lifting beams and rigging anchor point.
- » Threaded adjustment handle for easy mounting.
- » Adjustable to securely fit a wide range of flange widths and beams.
- » Lower headroom provided by built-in suspension bar
- » The width of jaws are designed to be equal for the best possible stability.
- » Special locking screw mechanism ensuring the unit stays tight, and thus increasing safety.
- » Comply with the latest Machinery Directive and EN safety standards.



WLL (ton)	Test Load (kN)	Beam Width (mm)
1	12.5	75-220
2	25	75-220
3	37.5	80-320
5	63	80-320
10	125	90-320



# ELECTRIC WINCH

## Model: MT-8000

8000lb(3629kg) 12V  
Heavy Duty Electric Winch

### Specification:

Rated line pull.....	8000lb(3629kg) single line
Motor.....	4.13KW/3.0HP 12V,Permanent magnet
Control.....	Remote switch,12ft(3.7m) lead
Gear train.....	3 Stage Planetary
Gear reduction ratio.....	195.8:1
Clutch.....	Sliding Ring Gear
Braking Action.....	Automatic In-The-Drum
Drum Dimensions.....	Φ2.6"x8.6"(Φ64mmx224mm)
Cable (Dia X L).....	Φ5/16"x94'(Φ8.1mmx28m)
Battery.....	Recommended:650CCA minimum for winching
Battery Leads.....	2 gauge,72"(1.83m)
Finish.....	Black powder coat
Overall dimensions.....	21.1"x6.3"x8.6"(537x160x218mm)
Mounting Bolt Pattern....	254mmx114.3mm
Packing size.....	57X19x34.5cm 1PC/CTN
Weight.....	N.W/G.W:33kg/35kg

### Line Speed and Amp Draw(First layer)12V

	lb	0	2000	4000	6000	8000
Line Pull	kg	0	907	1814	2721	3629
Line Speed	ft/min	22.5	11.48	8.53	8.53	5.0
	m/min	6.85	3.5	2.6	2.0	1.4
Motor	Amps	65	90	120	180	210

### Line Pull and Cable Capacity

Layers of cable		1	2	3	4
Rated line	lb	8000	6500	5500	4800
Pull per layer	kg	3629	2948	2495	2173
Cumulative	ft	19.6	42.6	68.9	92
Cable capacity	m	6.0	13	21	28

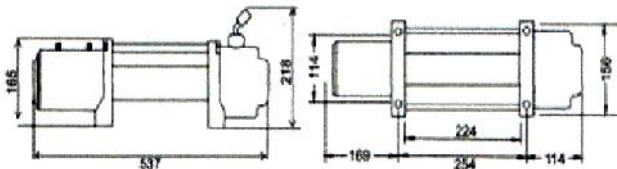



# ELECTRIC WINCH

## Model: MT-10000

**10000lb(4536kg) 12V  
Heavy Duty Electric Winch**

### Specification:

Rated line pull..... 10000lb(4536kg) single line  
 Motor..... 4.0KW/5.5HP 12V,4.8KW/6.44HP 24V, Series Wound  
 Control..... Remote switch,12ft(3.7m) lead  
 Gear train..... 3 Stage Planetary  
 Gear reduction ratio..... 148.2:1  
 Clutch..... Sliding Ring Gear  
 Braking Action..... Two-way, Automatic In-The-Drum  
 Drum Dimensions.....  $\Phi 2.5 \times 8.8$ "( $\Phi 64$ mmx224mm)  
 Cable (Dia X L).....  $\Phi 21/64 \times 94$ '( $\Phi 8.3$ mmx28m)  
 Rope (Dia X L).....  $\Phi 23/64 \times 94$ '( $\Phi 9$ mmx28m)  
 Fairlead..... 4-Way Roller Fairlead/Hawse Fairlead  
 Wireless Remote control..... Optional  
 Battery..... Recommended:650CCA minimum for winching  
 Battery Leads..... 2 gauge,72"(1.83m)  
 Finish..... Dark gray powder coat  
 Overall dimensions..... 21.1"x6.3"x8.6"(537x160x218mm)  
 Mounting Bolt Pattern..... 254mmx114.3mm  
 Packing size..... 57X19x34.5cm 1PC/CTN  
 Weight (cable winch)..... N.W/G.W:36.5kg/38.5kg  
 Weight (rope winch)..... N.W/G.W:26.5kg/28.5kg

#### Line Speed and Amp Draw(First layer)12V

Line Pull	lb	0	2000	4000	6000	8000	10000
	kg	0	907	1814	2721	3628	4536
Line Speed	ft/min	35.4	14.8	11.2	9.5	7.87	5.25
	m/min	10.8	4.5	3.4	2.9	2.4	1.6
Motor	Amps	75	180	220	290	360	420

#### Line Speed and Amp Draw(First layer)24V

Line Pull	lb	0	2000	4000	6000	8000	10000
	kg	0	907	1814	2721	3628	4536
Line Speed	ft/min	38.9	16.3	12.3	10.4	8.6	5.8
	m/min	11.9	4.9	3.7	3.2	2.6	1.8
Motor	Amps	50	100	145	190	230	290

#### Line Pull and Cable Capacity

Layers of cable	1	2	3	4	
Rated line	lb	10000	7930	6566	5604
Pull per layer	kg	4536	3596	2977	2541
Cumulative	ft	17	38.7	64.6	91.8
Cable capacity	m	5.2	11.8	19.7	28

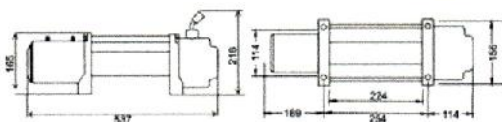

# ELECTRIC WINCH

## Model: MT-1 2000

**12000lb(5443kg) 12V  
Heavy Duty Electric Winch**

**Winch with 500A solenoid and latest gear box assembly & clutch handle**



### Specification:

Rated line pull.....	12000lb(5443kg) single line
Motor.....	4.8KW/6.6HP 12V, 5.0KW/6.65HP 24V, Series Wound
Control.....	Remote switch, 12ft(3.7m) lead
Gear train.....	3 Stage Planetary
Gear reduction ratio.....	187.2:1
Clutch.....	Keyway Cam
Braking Action.....	Two-way, Automatic In-The-Drum
Drum Dimensions.....	Φ2.5"x8.8"(Φ63.5mmx224mm)
Cable (Dia X L).....	Φ23/64"x90'(Φ9.1mmx27.5m)
Rope (Dia X L).....	Φ10mmx28m
Fairlead.....	4-Way Roller Fairlead/Hawse Fairlead
Wireless Remote control...	Optional
Battery.....	Recommended: 650CCA minimum for winching
Battery Leads.....	2 gauge, 72"(1.83m)
Finish.....	Dark gray powder coat
Overall dimensions.....	21.1"x6.3"x8.6"(537x160x218mm)
Mounting Bolt Pattern.....	254mmx114.3mm
Packing size.....	57X19x34.5cm 1PC/CTN
Weight (cable winch).....	N.W/G.W:37kg/39kg
Weight (rope winch).....	N.W/G.W:27kg/29kg

### Line Speed and Amp Draw(First layer)12V

Line Pull	lb	0	4000	6000	8000	10000	12000
	kg	0	1810	2720	3628	4540	5440
Line Speed	f/min	33.3	16.8	12.8	10.1	8.8	7.6
	m/min	10.3	5.1	3.9	3.1	2.7	2.3
Motor	Amps	85	158	231	302	371	420

### Line Speed and Amp Draw(First layer)24V

Line Pull	lb	0	4000	6000	8000	10000	12000
	kg	0	1810	2720	3628	4540	5440
Line Speed	f/min	35	18.5	14.4	11.5	10	8.9
	m/min	10.8	5.6	4.4	3.5	3.1	2.7
Motor	Amps	50	136	170	210	240	280

### Line Pull and Cable Capacity

Layers of cable		1	2	3	4
Rated line	lb	12000	9210	8030	6894
Pull per layer	kg	5443	4170	3640	3125
Cumulative	ft	17	41	71	91.8
Cable capacity	m	4.8	12	21	27.5

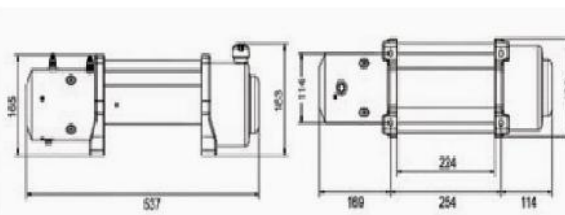

# ELECTRIC WINCH

## Model: MT-15000

**15000lb(6804kg)  
Heavy Duty Electric Winch**

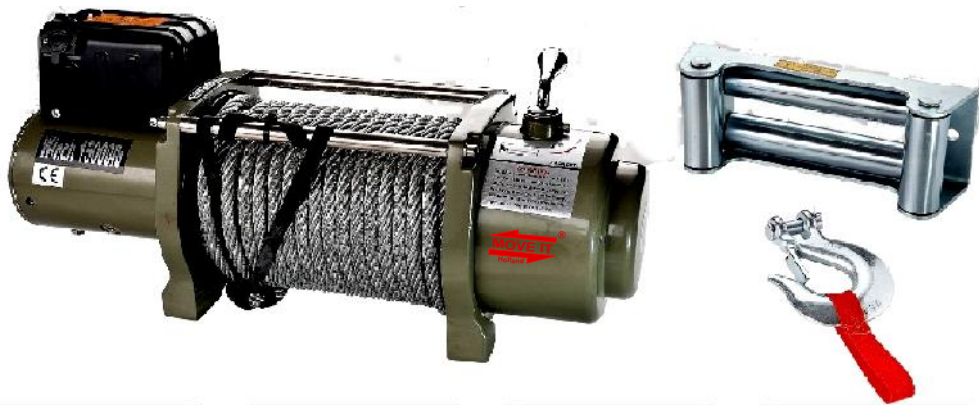

**Specification:**

Rated line pull.....	15000lb(6804kg) single line
Motor.....	4.2KW/5.7HP 12V 4.6KW/6.25HP 24V, Series Wound
Control.....	Remote switch, 12ft(3.7m) lead
Gear train.....	3 Stage Planetary
Gear reduction ratio.....	312:4:1
Catch.....	Sliding Ring Gear
Braking Action.....	Two way, Automatic In-The-Drum
Drum Dimensions.....	Φ3.59" x 3.72" (Φ85mm x 221.5mm)
Cable (Dia X L).....	Φ7/16" x 94' (Φ11mm x 28m)
Fairlead.....	4-Way Roller Fairlead
Wireless Remote control.....	Optional
Battery.....	Recommended 650CCA minimum for winching
Battery Leads.....	2 gauge, 72" (1.83m)
Finish.....	Dark gray powder coat
Overall dimensions.....	21.5" x 7.09" x 9.73" (547 x 180 x 247mm)
Mounting Bolt Pattern.....	254mm x 114.3mm
Packing size.....	60X25x38, 5cm 1PC/CTN
Weight.....	N.W/G.W:53kg/55kg

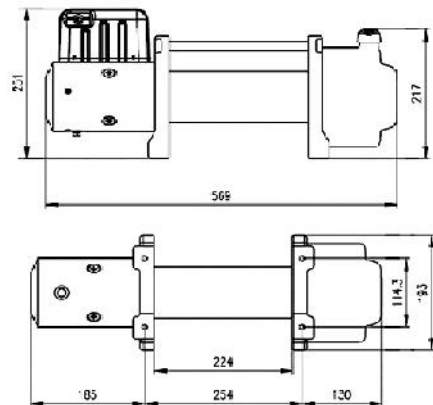

Line Speed and Amp Draw(First layer)12V

	lb	0	4000	6000	8000	10000	12000	15000
Line Pull	kg	0	1810	2720	3628	4540	5443	6804
Line Speed	ft/min	29.04	9.38	7.41	6.16	5.18	4.46	3.31
	m/min	7.3	2.86	2.26	1.91	1.68	1.36	1.01
Motor	Amps	75	167	136	246	283	340	430

Line Pull and Cable Capacity

Layers of cable	1	2	3	4	
Rated line	lb	15000	13775	11202	9058
Pull per layer	kg	6804	6250	5081	4245
Cumulative	ft	19.75	41.79	68.00	91.86
Cable capacity	m	6.02	12.74	20.15	28

Line Speed and Amp Draw(First layer)24V

	lb	0	4000	6000	8000	10000	12000	15000
Line Pull	kg	0	1810	2720	3628	4540	5443	6804
Line Speed	ft/min	25.6	9.7	7.79	6.4	5.4	4.6	3.44
	m/min	7.50	2.9	2.37	1.95	1.65	1.41	1.05
Motor	Amps	60	138	162	193	228	256	332



## ELECTRIC Winch

### Features & Benefits

- The Winch Brake is Equipped with Safety Electro-Hydraulic Block Brake, to Guarantee the Winch Work Safely.
- Final Drive Gears are Made of Heat Treated Carbon Steel, Offering Great Strength.
- Precision Needle Bearing used in High Load Areas offers Lower Friction Level and Longer Life.
- Superior Stainless Steel Front Plate Provides Rust Resistance.
- High Impact Case Provides Weather Resistance and Protection for Internal Components.
- The Winch Drum is Made from Q345B Steel Plate.
- All the Mechanical Parts are Detected by Flaw Detection.
- ICE Induction Motor, Electro Magnetic Brake System Rope End Stopper is Sliced for Safety.
- Used in Construction, Marine and Oilfield Industries.



Model	Load Capacity	Rated Speed	Drum Capacity	Voltage	Motor Protection Case	Dimension	Physical Weight
MTK 1000	1 TON	13M/MIN	100M	3 Phase 380V,50Hz	IP55	1060x430x710	212 kg
MTK 2000	2 TON	14M/MIN	150M	3 Phase 380V,50Hz	IP55	1360x530x710	407 kg
MTK 3000	3 TON	12M/MIN	200M	3 Phase 380V,50Hz	IP55	1660x640x870	687 kg

## ELECTRIC Building Winch

### Features & Benefits

- The Winch Brake is Equipped with safety Electro-Hydraulic Block Brake, to grantee the winch work safely.
- Final drive gears are made of heat treated carbon steel, offering great strength.
- Precision needle bearing used in high load areas.
- Offering lower friction level and longer life.
- Superior stainless steel front plate provides rust resistance.
- High impact case provides weather resistance & protection for internal components.
- The winch drum is made from Q345B steel plate.
- ICE Induction motor, electro magnetic brake system rope end stopper is sliced for safety
- Used in construction, Marine & oilfield Industries.



Model	Description	Rated Load (KN)	Rated Speed (m/min)	Rope Capacity (m)	Rope Diameter (mm)	Motor Power (KW)
MT5500	5 Ton Electric Winch Building Type	50	10	200	21.5	11
MT1000	10 Ton Electric Winch Building Type	100	8	250	30	22

## Polyester Webbing Sling

CITEX Polyester Webbing Sling are made of strong polyester adhere to 7:1 safety factor and is manufactured according to BS 3481 part 2 and it fulfils the S.W.L. (Safe Working Load) as stated on the label, which is attached to every sling



Technical Specification			FLAT POLYESTER WEBBING SLINGS SINGLE PLY STANDARD : BS: 3481 PART 2 SAFETY FACTOR : 7:1					
KGS	COLOUR	WIDTH	LOAD CAPACITIES IN KGS			LIFTING AN ANGLE		
			100%	200%	80%	7" - 45"	45 - 60"	
500	VIOLET	1 inch	500	1000	400	700	500	
1000	GREEN	2 inch	1000	2000	800	1400	1000	
1500	YELLOW	3 inch	1500	3000	1200	2100	1500	
2000	GREY	4 inch	2000	4000	1600	2800	2000	
2500	RED	5 inch	2500	5000	2000	3500	2500	
3000	BROWN	6 inch	3000	6000	2400	4200	3000	
4000	BLUE	8 inch	4000	8000	3200	5600	4000	
5000	ORANGE	10 inch	5000	10,000	4000	7000	5000	
6000	ORANGE	12 inch	6000	12,000	4800	8400	6000	

Technical Specification			FLAT POLYESTER WEBBING SLINGS DOUBLE PLY STANDARD : BS: 3481 PART 2 SAFETY FACTOR : 7:1					
KGS	COLOUR	WIDTH	LOAD CAPACITIES IN KGS			LIFTING AN ANGLE		
			100%	200%	80%	7" - 45"	45 - 60"	
1000	VIOLET	1 inch	1000	2000	800	1400	1000	
2000	GREEN	2 inch	2000	4000	1600	2400	2000	
3000	YELLOW	3 inch	3000	6000	2400	4200	3000	
4000	GREY	4 inch	4000	8000	3200	5600	4000	
5000	RED	5 inch	5000	10,000	4000	7000	5000	
6000	BROWN	6 inch	6000	12,000	4800	8400	6000	
8000	BLUE	8 inch	8000	16,000	6400	11,200	8000	
10,000	ORANGE	10 inch	10,000	20,000	8000	14,000	10,000	
12,000	ORANGE	12 inch	12,000	24,000	9600	16,800	12,000	

Technical Specification			FLAT POLYESTER WEBBING SLINGS 3 PLY STANDARD : BS: 3481 PART 2 SAFETY FACTOR : 7:1					
KGS	COLOUR	WIDTH	LOAD CAPACITIES IN KGS			LIFTING AN ANGLE		
			100%	200%	80%	7" - 45"	45 - 60"	
1500	VIOLET	1 inch	1500	3000	1200	2100	1500	
3000	GREEN	2 inch	3000	6000	2400	4200	3000	
4500	YELLOW	3 inch	4500	9000	3600	6300	4500	
6000	GREY	4 inch	6000	12,000	4800	8400	6000	
7500	RED	5 inch	7500	15,000	6000	10,500	7500	
9000	BROWN	6 inch	9000	18,000	7200	12,600	9000	
12,000	BLUE	8 inch	12,000	24,000	9600	16,800	12,000	
15,000	ORANGE	10 inch	15,000	30,000	12000	21,000	15,000	
18,000	ORANGE	12 inch	18,000	36,000	14400	25,200	18,000	

Technical Specification			FLAT POLYESTER WEBBING SLINGS 4 PLY STANDARD : BS: 3481 PART 2 SAFETY FACTOR : 7:1					
KGS	COLOUR	WIDTH	LOAD CAPACITIES IN KGS			LIFTING AN ANGLE		
			100%	200%	80%	7" - 45"	45 - 60"	
2000	VIOLET	1 inch	2000	4000	1600	2,800	2000	
4000	GREEN	2 inch	4000	8000	3200	5,600	4000	
6000	YELLOW	3 inch	6000	12,000	4800	8,400	6000	
8000	GREY	4 inch	8000	16,000	6400	11,200	8000	
10,000	RED	5 inch	10,000	20,000	8000	14,000	10,000	
12,000	BROWN	6 inch	12,000	24,000	9,600	16,800	12,000	
16,000	BLUE	8 inch	16,000	32,000	12,800	22,400	16,000	
20,000	ORANGE	10 inch	20,000	40,000	16,000	28,000	20,000	
24,000	ORANGE	12 inch	24,000	48,000	19,200	33,600	24,000	

## ROUND SLING

- Protected with strong fabric;
- Available single cover and double cover;
- Manufactured according to EN 1492-2;
- With CE & GS Certificate issued by TUV.
- Safety Factor 7:1;
- Material 100% polyester;

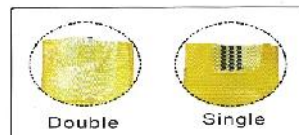
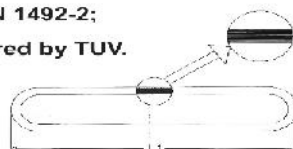

**CARGO LASHINGS**

CITEX Cargo lashings are made of high strength polyester webbings and are suitable for almost every kind of transport. The width of the webbing is 25 mm, 50 mm, 75mm & 100mm both the ratchet and the webbing have a capacity of 1.5 Ton, 05 Ton, 08 Ton and 10 Ton respectively. The ratchet and fittings are made of the highest quality hardened steel.



Size	Breaking strength
2" X 10 MTR	3 TON
2" X 10 MTR	5 TON
3" X 10 MTR	10 TON
4" X 10 MTR	12 TON

**RING**



**RATCHET**

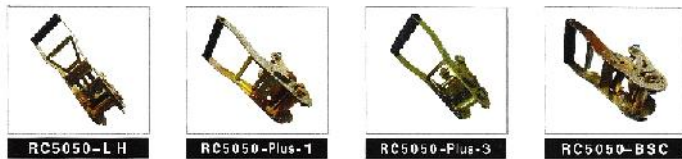

**HOOK**



**HOOK**

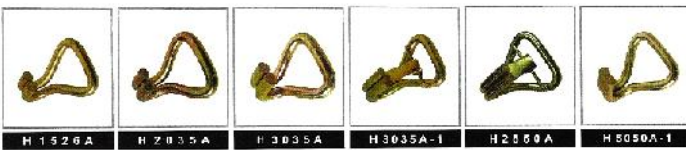

**BUCKLE**



**POLYESTER WEBBING NET**

Model	NETS0.9 x 1.3
Size	0.9m x 1.3m
Webbing width	35mm
LC	1000daN
Color	orange/other

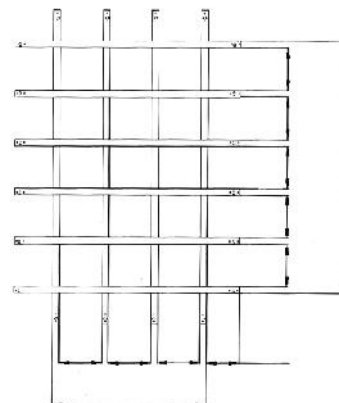

**Move It** designs and manufactures a wide variety of webbing nets for interior truck and trailer. These nets are tailored to fit each application resulting in a highly effective load securing system.



## Ratchet Puller | Ratchet Grip



Move It-Holland ratchet puller is designed for conductor and cable tensioning applications within the electricity distribution and telecommunication industry.

### Features

- » Compact design, light weight and easily carried.
- » Fast advance mechanism.
- » Equipped with automatic mechanical brake and change pawl.
- » More built-in safety factors than other brands.
- » Easily field repairable and inexpensive for maintenance.
- » Solid ductile and malleable iron construction.
- » Integrated gear, more wear-resistant for use.
- » Integral type die-casting sheave for smooth operation.
- » Yellow zinc-plated finish protects components from rust and corrosion.
- » 360° handle movement.

45" forged hook c/w safety latch

Integral type die-casting sheave

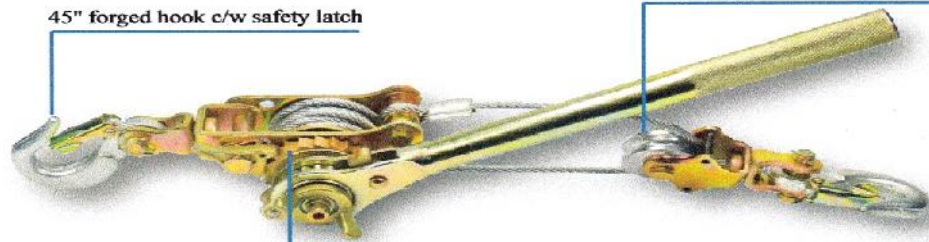

Integrated gear, more wear-resistant

Pulling Capacity (kg)	Lever Length (mm)	Max. Tension Length (mm)	Min. Tension Length (mm)	Numbers of Hooks	Wire Rope (mm x mtr)
0.5	330	1370	360	2	5 x 1.2
1	330	1230	410	2	5 x 2.2
1.5	430	1250	450	2	6 x 2.2
2	430	1870	480	2	6 x 3.2

## Wire Rope & Cable Grip



Move It-Holland wire grip can be used with ratchet puller, to grip, pull and tension wire rope, cable and metal rods, etc.

### Features

- » Light weight and compact design, easy for carrying.
- » Made from drop forged alloy steel for durability and toughness.
- » Parallel jaws provide firm grip without damaging wire rope/cable.
- » Guide prevents the grip from dropping off wire rope/cable and allows instant release.
- » Grips open easily and release instantly to quick insert or remove wire rope/cable.
- » Yellow zinc-plated finish protects components from rust and corrosion.
- » Large handle eye opening accepts standard hooks and easily attached to tackle blocks or strap pullers.



W.L.L. (kg)	Grip Range (mm)	Package Size (mm)	Q'ty/CTN (pcs)	N.W. (kg)
500	1-10	185x170x130	10	0.4
1000	2.6-15	240x210x140	10	0.8
2000	4-22	270x260x110	5	1.5
3000	16-32	370x350x180	5	2.3

## HAND PULLER



Model	MT-1000	MT-2000	MT-3000	MT-4000
Maximum pulling capacity (ton)	1 (double line) 0.5 (single line)	2 1	3 1.5	4 2
Steel cable diameter (mm)	Φ4.5	Φ4.8	Φ5	Φ5.5
Steel cable length (m)	1.8	3	3	3
Effective towing distance (m)	0.7	1.2	1.2	1.2
Leverage	15:1	15:1	15:1	15:1
Q'ty/Cartron (pieces)	10	6	6	4
Package size (cm)	56x42x22	61x26x22	65x28x26	71x21x29
G.W./N.W. (kg)	22/20	17/15	22/20	22/20
Remark	single gear, 2 hooks	double gear, 2 hooks	double gear, 2 hooks	double gear, 2 hooks

## Mechanical Jack | Rack and Pinion Jack



Move It-Holland mechanical jacks are primarily used for assembly applications, to brace or support loads.

It can basically used to lift almost all kinds of loads in maintenance and repair, ship building, construction as we as agriculture.

### Feature

- » Sturdy structure, light weight, easily handling.
- » Low gearing tolerance - smooth transmission, free of jerks.
- » Lifting claw adjustable in different positions.
- » Collapsible handle for easy storage, operation and maintenance.
- » Sensitive brake system, quick braking, safe and reliable.
- » Quick lift performance makes it work more efficiently.
- » Conforms to the latest Machinery Directive and EN standards

Model	W.L.L. (ton)	Test Load (kN)	Hand Pull to Lift Full Load (N)	The Number of Operator	Dimension (mm)												N.W. (kg)
					A	B	C	D	E	F	G	H	K	R	S	T	
MJ030	3	36.8	196	1	83	130	720-1075	55-410	60	45	138	285	200	140	230	126	21.3
MJ050	5	61.3	235	1	105	140	735-1065	60-390	70	68	175	285	190	155	220	126	27
MJ100	10	122.5	431	2	120	140	795-1155	70-430	80	73	175	330	252	185	220	250	47
MJ160	16	196	580	2	153	150	790-1105	90-405	85	90	182	360	275	210	202	250	64.5
MJ200	20	245	650	2	153	150	840-1155	90-405	85	90	182	360	275	224	202	250	72
MJ250	25	306	750	2	153	198	850-1360	110-520	85	90	230	360	388	200	205	250	93

## Brano Mechanical Jack

### Uses:

- For lifting and manipulation with load
- For assembly work of all kind
- Also in variant for use in explosive environment (marking NEXP)



### MAIN SPECIFICATIONS

Type	Load capacity (t)		Actuating force on crank (N)		Range of Operating temperature	Weight (kg)
	Q	Q <sub>1</sub>				
15-00 15-00-RK 15-00-VK 15-00-VK-RK	2.5	1,75	380		-20°C till +50°C	15
15-00 15-00-RK 15-00-VK 15-00-VK-RK	5	3,5	550			22
HZ	5	3,5	550 <sup>1)</sup>	330 <sup>2)</sup>		23
15-01 15-01-RK 15-01-VK 15-01-VK-RK	10	7	540			38
15-01	16	11,2	730			65
Z 23	20	14	800			90

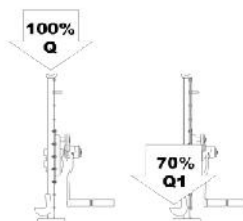

Fig. 1



## Hydraulic Industrial Toe Jack

CE

Move It-Holland offers a range of high quality industrial toe jacks from 5ton to 25ton. These toe jacks can be used to raise loads and place skates underneath them as well as for general repair or maintenance and for installation of heavy items(eg factory machinery, containers etc).

All of our jacks have dual lifting capacities: you can lift by using the toe or the head of the jack.

### Features

- » Industrial quality, heavy-duty type.
- » With compact and stable structure.
- » No chaining trouble.
- » Usable in any position.
- » Alloy steel valve body appears more artistic and handy.
- » While the toe is higher than the base, then cylinder can be rotated in 360 degrees.
- » Lowering speed can be accurately adjusted.
- » Equipped with safety valve for overload protection.
- » Convenient and rotatable handle hub for easy operation in any direction.
- » The base is alloy steel forged, to make sure high strength.
- » Conforms to the latest Machinery Directive and EN safety standards.



Model	Rated capacity (kg)	Lifting stroke on toe (mm)	Lifting stroke on head (mm)	Effort on handle (N)	Net weight (kg)	Package size (cm)
MT 5K	5000	25-230	368-573	≤380	25	36.5x20x43
MT 10K	10000	30-260	420-650	≤400	35	38x22.5x48.5
MT 25K	25000	58-273	505-720	≤400	102	54x32x61.5

## Bottle jack



CE

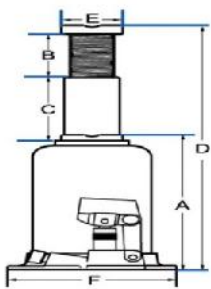

Model	Rated Capacity	A	B	C	D	E	F	Packaging	Package Size
		(mm)	(mm)	(mm)	(mm)	(mm)	(mm)		
MT902001	2ton	172	88	112	372	28	103x105	Color Box	130x110x185
MT903001	3ton	172	88	112	372	28	103x105	Color Box	130x110x185
MT905001	5ton	218	110	146	474	32	110x112	Color Box	135x120x225
MT910001	10ton	220	115	153	488	48	124x127.5	Color Box	150x145x230
MT915001	15ton	228	113	160	508	56	140x142	Color Box	165x150x240
MT920001	20ton	241	110	165	525	60	165x161	Color Box	180x170x250
MT925001	25ton	240	110	157	510	65	186x174	Color Box	195x185x270
MT930001	30ton	244	110	160	510	65	186x174	Color Box	195x185x270

An Overseas association Member of Lifting Equipment Engineers Association  
UK & ISO 9001 Company

**EN 13414-1 Wire Standard**

Working load limits (T)	One-leg sling	Two-leg sling		Three and four-leg sling		Endless sling
	Angle to the vertical	0° to 45°	over 45° to 60°	0° to 45°	over 45° to 60°	0°
Nominal rope Diameter mm						
	Steel Core	Steel Core	Steel Core	Steel Core	Steel Core	Steel Core
8	0.82	1.15	0.82	1.72	1.23	1.31
9	1.04	1.45	1.04	2.18	1.56	1.66
10	1.28	1.79	1.28	2.69	1.92	2.05
11	1.55	2.17	1.55	3.25	2.32	2.48
12	1.84	2.57	1.84	3.85	2.75	2.94
13	2.17	3.03	2.17	4.55	3.25	3.47
14	2.15	3.52	2.51	5.28	3.77	4.02
16	3.29	4.6	3.29	6.9	4.93	5.26
18	4.15	5.81	4.15	8.17	6.22	6.64
20	5.12	7.17	5.12	10.75	7.68	8.19
22	6.2	8.69	6.2	13.03	9.31	9.93
24	7.38	10.33	7.38	15.5	11.07	11.81
26	8.66	12.13	8.66	18.19	13	13.86
28	10.04	14.06	10.04	21.08	15.06	16.06
32	13.12	18.37	13.12	27.56	19.69	21
36	16.59	23.23	16.59	34.84	24.89	26.55
40	20.56	28.78	20.56	43.17	30.84	32.89
44	24.78	34.69	24.78	52.04	37.17	39.65
48	29.55	41.37	29.55	62.06	44.33	47.28
52	34.69	48.57	34.69	72.85	52.04	55.51

**STEEL WIRE ROPE COMBINATIONS**

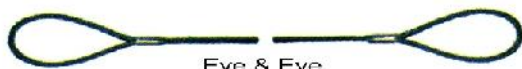

Eye & Eye



Eye & Thimble



Thimble Hook



Thimble & Thimble

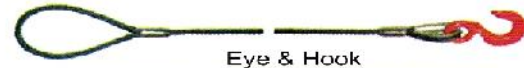

Eye & Hook



Endless Sling



2 Leg With Soft Eye

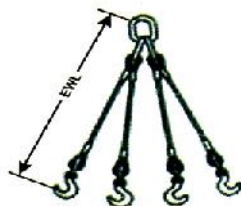

4 Leg With End Fittings



4 Leg With Soft Eye



An Overseas Associate Member of Lifting Equipment Engineers Association  
UK & ISO 9001 Company

**Grade 80 CHAIN SLING CHART (BS EN 818 - 4)**

Chain Size	Single Leg	Two Leg Angle from leg to vertical		Three/ Four Leg Angle from leg to vertical	
	90°	0. To 45°	45° To 60°	0. To 45°	45° To 60°
8mm	2.00	2.00	2.00	4.25	3.00
10mm	3.15	4.25	3.15	6.70	4.74
13mm	5.30	7.50	5.30	11.20	8.00
16mm	8.00	11.20	8.00	17.00	11.80
18mm	10.00	14.00	10.00	21.25	14.75
20mm	12.50	17.50	12.50	28.50	19.00
22mm	15.00	21.20	15.00	31.50	22.40
26mm	21.20	30.00	21.20	45.00	31.50
32mm	31.50	45.00	31.50	67.00	47.50

Working Load Limit In Tonnes

\* All slings are provided with Anodised Aluminium Tag and Test Certificates

**CHAIN SLING COMBINATIONS**



Endless



Single Leg



Two Leg  
(With Grab Hook)



Three Leg



Four Leg  
(With Shortening Clutch)

**CHAIN SLING ACCESSORIES**



Masterlink For  
1 & 2 Leg



Masterlink For  
Assly For 3/4 Leg



Connecting Link



Shortening  
Clutch



Clevis Grab  
Hook



Clevis Hook  
With Latch



Clevis Self-  
Locking Hook



Swivel Self  
Lock Hook



Ratchet  
Load Binder



Lever  
Load Binder

Accord to SFS/EN-818  
Safety Factor: 4:1

## Rigging Hardware



Specification  
6-8  
7/8-8  
10-8  
13-8  
16-8  
20-8  
22-8  
26-8  
32-8

Eye Grab Hook



Specification  
6-8  
7/8-8  
10-8  
13-8  
16-8

Clevis shortening grab hook



Specification  
6-8  
7/8-8  
10-8  
13-8  
16-8  
20-8

Eye Sling Hook with Latch



Specification  
6-8  
7/8-8  
10-8  
13-8  
16-8  
20-8

Clevis Sling Hook with Latch



Specification  
6-8  
7/8-8  
10-8  
13-8  
16-8

Eye Foundry Hook



Specification  
6-8  
7/8-8  
10-8  
13-8  
16-8  
20-8

Eye Swivel Hook with Latch



Specification  
6-8  
7/8-8  
10-8  
13-8  
16-8  
20-8  
22-8  
26-8

Eye Self-Locking Hook



Specification  
6-8  
7/8-8  
10-8  
13-8  
16-8  
20-8

Clevis Self-Locking Hook



Specification  
1-T  
3T  
5T  
8T

Weld On Hook



Specification  
6-8  
7/8-8  
10-8  
13-8

Clevis Shortening Clutch



Specification  
M6  
M8  
M10  
M12  
M16  
M20  
M24  
M30  
M36  
M42

Eye Bolt



Specification  
M6  
M8  
M10  
M12  
M16  
M20  
M24  
M30  
M36  
M42

Eye Nut



Specification  
6-8  
7/8-8  
10-8  
13-8  
16-8  
20-8  
22-8

Weld Master Link



Specification  
6-8  
7/8-8  
10-8  
13-8  
16-8  
20-8

Welded Master Link Assembly



Specification  
6-8  
7/8-8  
10-8  
13-8  
16-8  
20-8  
22-8

Welded Master Link With Flat



Specification  
6-8  
7/8-8  
10-8  
13-8  
16-8  
20-8

Welded Master Link Assembly With Flat



Specification  
6-8  
7/8-8  
10-8  
13-8  
16-8  
20-8  
22-8

Connecting Link



Specification  
6-8  
7/8-8  
10-8  
13-8  
16-8

Web Sling Connector



Specification  
6-8  
7/8-8  
10-8  
13-8

Omega Link



Lift Ring



## Bow Shackle With Screw Pin

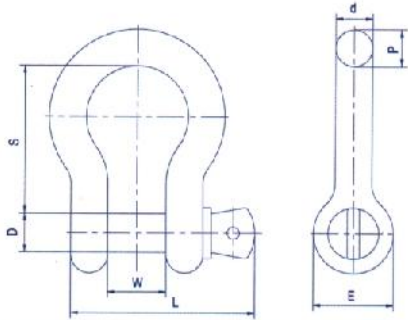

Art. No	WLL	W	D	d	E	P	S	L	Self Weight
MT 05-1/4	0.5	12	8	6.5	15.5	----	29	36.5	0.05
MT 0.75-5/16	0.75	13.5	10	8	19	----	31	44.5	0.1
MT 1-3/8	1	17	12	9.5	23	----	36.5	52.5	0.13
MT 1.5-7/16	1.5	19	14	11	27	----	43	62	0.21
MT 2-1/2	2	20.5	16	13	30	----	48	70.5	0.3
MT 3.25-5/8	3.25	27	20	16	38	17.5	6.5	88	0.64
MT 4.75-3/4	4.75	32	22	19	46	20.5	71.5	102.5	1.09
MT 6.5-7/8	6.5	36.5	27	22.5	53	24.5	84	121	1.7
MT 8.5-1	8.5	43	30	25.5	60.5	27	95	139	2.5
MT 9.5-1 1/8	9.5	46	33	29.5	68.5	32	108	154	3.79
MT 12-1 1/4	12	51.5	36	33	76	35	119	170.5	4.89
MT 13.5-1 3/8	13.5	57	39	36	84	38	133.5	188.5	7.04
MT 17-1 1/2	17	60.5	42	39	92	41	146	201	8.35
MT 25-1 3/4	25	73	52	47	106.5	57	178	244	13.72
MT 35-2	35	82.5	60	53	122	61	197	275	20.33
MT 55-2 1/2	55	105	70	69	144.5	79.5	267	346	40.92



## Bow Shackle Bolt Type

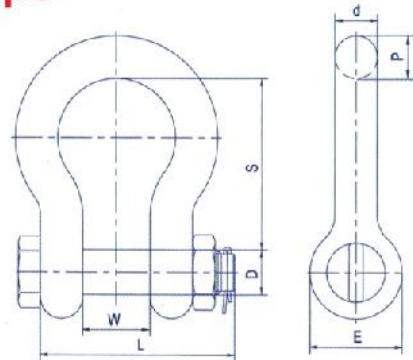

Art. No	WLL	W	D	d	E	P	S	L	Self Weight
MT 05-1/4	0.5	12	8	6.5	15.5	----	29	37	0.05
MT 0.75-5/16	0.75	13.5	10	8	19	----	31	45	0.10
MT 1-3/8	1	17	12	9.5	23	----	36.5	54	0.15
MT 1.5-7/16	1.5	19	14	11	27	----	43	62	0.22
MT 2-1/2	2	20.5	16	13	30	----	48	71.5	0.36
MT 3.25-5/8	3.25	27	20	16	38	17.5	6.5	89	0.76
MT 4.75-3/4	4.75	32	22	19	46	20.5	71.5	105	1.23
MT 6.5-7/8	6.5	36.5	27	22.5	53	24.5	84	121	1.79
MT 8.5-1	8.5	43	30	25.5	60.5	27	95	136.5	2.57
MT 9.5-1 1/8	9.5	46	33	29	68.5	32	108	149.5	3.75
MT 12-1 1/4	12	51.5	36	32	76	35	119	164.5	5.31
MT 13.5-1 3/8	13.5	57	39	35	84	38	133.5	179	7.18
MT 17-1 1/2	17	60.5	42	38	92	41	146	194.5	9.43
MT 25-1 3/4	25	73	52	44.5	106.5	57	178	234	15.4
MT 35-2	35	82.5	58	51	122	61	197	262.5	23.7
MT 55-2 1/2	55	105	70	66.5	144.5	79.5	267	339	44.6
MT 85-3	85	127	85	76	165	92	330	394	70

## D Shackle With Screw Pin

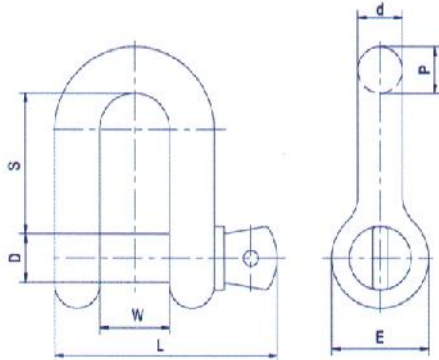

Art. No	WLL	W	D	d	E	P	S	L	Self Weight
MT 05-1/4	0.5	12	8	6.5	15.5	---	22	38.5	0.04
MT 0.75-5/16	0.75	13.5	10	8	19	---	26	44.5	0.08
MT 1-3/8	1	17	12	9.5	23	---	32	52.5	0.13
MT 1-5-7/16	1.5	19	14	11	27	---	36.5	62	0.2
MT 2-1/2	2	20.5	16	13	30	---	41.5	70.5	0.27
MT 3.25-5/8	3.25	27	20	16	38	---	51	88	0.57
MT 4.75-3/4	4.75	32	22	19	46	20.5	60.5	102.5	0.99
MT 6.5-7/8	6.5	36.5	27	22.5	53	24.5	71.5	115	1.57
MT 8.5-1	8.5	43	30	25.5	60.5	---	81	139	2.3
MT 9.5-1 1/8	9.5	46	33	29	68.5	32	91	153	3.42
MT 12-1 1/4	12	51.5	36	32	76	35	100	168.5	4.48
MT 13.5-1 3/8	13.5	57	39	35	84	38	111	184.5	6.46
MT 17-1 1/2	17	60.5	42	38	92	41	122	199	7.65
MT 25-1 3/4	25	73	52	44.5	106.5	54	146	237	12.48
MT 35-2	35	82.5	60	51	122	---	171.5	271	18.83
MT 55-2 1/2	55	105	70	66.5	144.5	---	203	341	36.02

## D Shackle Bolt Type

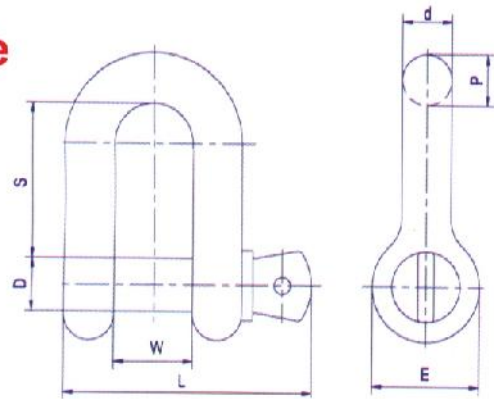
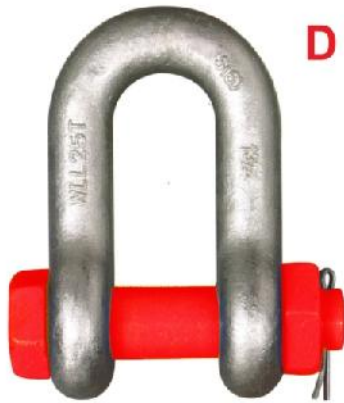

Art. No	WLL	W	D	d	E	P	S	L	Self Weight
MT 05-1/4	0.5	12	8	6.5	15.5	---	22	37	0.06
MT 0.75-5/16	0.75	13.5	10	8	19	---	26	45	0.1
MT 1-3/8	1	17	12	9.5	23	---	32	54	0.15
MT 1-5-7/16	1.5	19	14	11	27	---	36.5	62	0.22
MT 2-1/2	2	20.5	16	13	30	---	41.5	71.5	0.34
MT 3.25-5/8	3.25	27	20	16	38	---	51	89	0.67
MT 4.75-3/4	4.75	32	22	19	46	20.5	60.5	105	1.14
MT 6.5-7/8	6.5	36.5	27	22.5	53	24.5	71.5	121	1.76
MT 8.5-1	8.5	43	30	25.5	60.5	---	81	136.5	2.58
MT 9.5-1 1/8	9.5	46	33	29	68.5	32	91	149.5	3.45
MT 12-1 1/4	12	51.5	36	32	76	35	100	164.5	5.06
MT 13.5-1 3/8	13.5	57	39	35	84	38	111	179	7.29
MT 17-1 1/2	17	60.5	42	38	92	41	122	194.5	8.75
MT 25-1 3/4	25	73	52	44.5	106.5	54	146	234	14.22
MT 35-2	35	82.5	58	51	122	---	171.5	262.5	21
MT 55-2 1/2	55	105	70	66.5	144.5	65.5	203	339	42.12
MT 85-3	85	127	85	76	165	89	216	394	65.3





# Split Frame Cold Cutting & Beveling Machine

SOLUTION FOR PRECISION PIPE CUTTING & BEVELLING

- Oil & Gas
- Petro Chemical
- Nuclear Power Plants
- Mining Industries
- Pharmaceutical
- Fabrication



## Features

- Cuts and Bevels varied Pipe Thickness with just change of Interchangeable bits
- Portable - External Mountable of its type for Pipe Cutting and Beveling Applications
- Low Friction adjustable Bearing provides maximum Stability and Extended Machine Life
- Bearing and Sliding Parts are totally enclosed for Operational Safety and Long Life
- Easily Splits into halves to mount on the Outside diameter of the Pipes on-Line
- Cutting & Beveling can be done in single set up or else two tool bits for same operation can be used
- Available in Pneumatic, Hydraulic and Electrical Drive .
- Bevels and Cuts material Like MS, Carbon Steel, Alloy steels, stainless steels, Inconel, etc
- Size range : 3/4" - 03", 03" - 08", 06" - 12", 10"-16", 18"-24", 26"-32", 36"- 42", 40"-48" & Above

Model	Nom. Pipe		ID of Machine	Radial Clearance	Axial Clearance	Nett Wt
	MM	Inche				
MTOP0103	20-89	3/4"-03"	94	126.5	159.5	16
MTOP0205	50-159	02"-05"	165	195	171.6	30
MTOP0308	80-230	03"-08"	236	232	171.6	53
MTOP0510	125-275	05"-10"	281	245	171.6	54
MTOP0612	168-325	06"-12"	331	281.5	171.6	68
MTOP0814	219-317	08"-14"	386	309	171.6	71
MTOP1016	273-426	10"-16"	432	324.25	172.6	75
MTOP1218	300-457	12"-18"	464	349.5	172.6	84
MTOP1420	355-508	14"-20"	515	374.5	181.6	88
MTOP1824	457-610	18"-24"	618	426	182.6	120
MTOP2430	600-762	24"-30"	770	502.5	185.1	152
MTOP2632	660-813	26"-32"	840	534.5	187.5	164
MTOP3036	762-914	30"-36"	924	581.5	194	170
MTOP3642	914-1066	36"-42"	1077	662.5	194	192
MTOP4048	1016-1230	40"-48"	1248	754	207	226

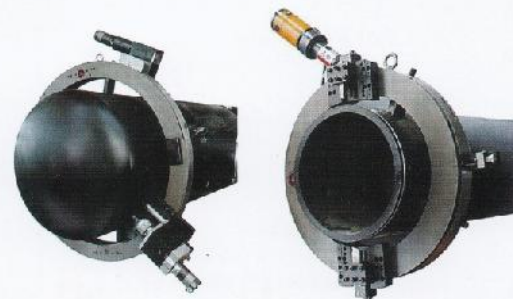

## Specifications

- Feed Method : Auto - Star Wheel
- Feed Rate : 0.06 mm/0.0025"
- Wall Thickness : < 30 mm (Without Reset the Tool Bits)

## Drivers :

- Air / Pneumatic : 0.6 - 0.8 Mpa 1500 - 2000 Lit/Min
- Electric : 220 Volts, 50/60 HZ, 6/12 Amps, : 1000-2000 W
- Hydraulic : 380 Volts - 3 Phase, 12.5 Mpa, : 2-60 Lit/ Min



## MACHINE BODY SIZE

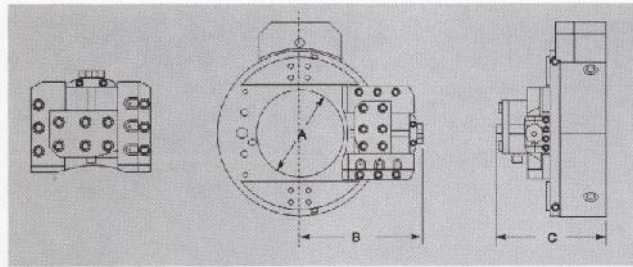

Model Specifications	80	150	300	450	600	750	900	1050	1160	1300	1500
A DIM (mm)	85	166	306	458	606	753	910	1060	1170	1306	1505
B DIM (mm)	171	230	309	385	458	532	613	688	772	840	940
C DIM (mm)	161	161	175	175	175	175	175	175	221	221	221

## ID Mount End Prep Beveling

The ID Mounted beveling operation utilizes an expandable mandrel which is slid into the open end of the pipe. A draw nut is tightened, which expands the mandrel blocks up a ramp and against the ID surface for positive mounting, self centered and squared to the bore. As the tool bit is fed in to the material from the end, bevel is produced which conforms to the angle predetermined by the angle ground in to the bit. Bits are available for practically any material or beveling required, and bits can be custom made for any form tooling operation.

## Features

Cold Beveling  
Fast, Precision, On-site Beveling  
minimal Axial and Radial clearance  
Light weight and compact design  
Easy set-up & robust operation  
Electric or Pneumatic drive



### Technical Parameter

Electric	Pneumatic	Working range(I.D. mm)	Wall thickness (mm)	Rotating rate (rpm)
MTE-101	MTP-201	Φ 85-240	≤75	16
MTE-102	MTP-202	Φ 150-330	≤75	14
MTE-103	MTP-203	Φ 300-600	≤75	10
MTE-104	MTP-204	Φ 600-820	≤75	8
MTE-105	MTP-205	Φ 820-1020	≤75	7
MTE-106	MTP-206	Φ 1015-1255	≤75	5
MTE-107	MTP-207	Φ 1270-1470	≤75	4

## FEATURES

This machine is researched and manufactured according to the operation of long-distance pipeline and flange. We have independent intellectual property. Outside calipers is fixed in proper position, high stiffness of structural support, fulfill the wide cutting range, easy operation, high efficiency. It can process chute/flume/sealing surface and blank flange, tube-plate of heat exchange.

Swivel Tool post with 360° power feed, wide range use.

Feed handwheel of horizontal and vertical tool post with scale, precise and convenient regulation.

Tool post can feed automatically in both axial and radial, processed precision is guaranteed.

Adjustable hydraulic drive motor, adjustable speed, strong power, meets different requirements of customers.

Maximum depth of roughing processing is 1.5mm.

Pneumatic motor is optional, used for proof-explosion on-site operation.

## FLANGE FACING MACHINE

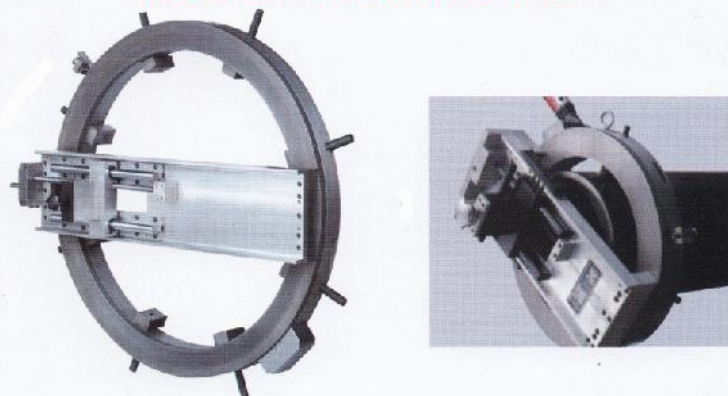



## Hydraulic Pipe Bender With Hinged Frame



Manual for long radius

Prod. No.	Size in Inches	Pump Force in Tons	N. Wt (Kgs)	G. Wt. (Kgs)
MT 213 A	1/2 - 2	15	98.0	110.0
MT 213 C	1/2 - 3	16	143.0	163.0
MT 213 D	1 - 4	20	312.0	390.0
MT 213 E	2 - 6	20	368.0	482.0

## Hydraulic Motorised Pipe Bender With Hinged Frame With Power Pack

Motorised with power pack for long radius heavy gauge pipe bending for size 1/2" to 12" gas, water, steam DIN 2440/2441 up to 90° bending.



Prod. No.	Size in Inches	Motor Power/KW III Phase 440 V II Phase 220/110V on request	N. Wt. (Kgs)	G. Wt. (Kgs)
MT 212 A	1/2 - 2	1.5	165.0	250
MT 212 B	1/2 - 3	1.5	220.0	300
MT 212 C	1 - 4	1.5	390.0	540
MT 212 D	2 - 6	1.5	447.0	628
MT 212 E	4 - 8	5.0	--	--
MT 212 F	6 - 12	7.5	--	--

## Pipe Benders

### Spare Bending Formers of Hinged Frame

For long radius heavy gauge bending ideally suitable for "C" class (Sch. 40 pipe) size 3/8" to 6" gas water, steam DIN 2440/2441 up to 90° bending.



M.S. Formers

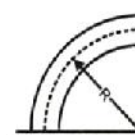

Bending radius R is always calculated from the middle of the pipe

Prod. No.	O.D. inches	O.D. ERW mm	Wall Thck. (ERW) mm	O.D. Sch. 40/80mm	Wall Thck. Sch. 40/80mm	Radius mm	N.wt. (Kgs) C.I	V.S
MT 214 A	3/8	16.7	3.25	-	-	95	1.250	2.360
MT 214 B	1/2	21.0	3.25	21.3	2.7 - 3.7	95	1.200	2.300
MT 214 C	3/4	26.4	3.25	26.6	2.8 - 3.9	95	1.200	2.150
MT 214 D	1	33.2	4.05	33.4	3.3 - 4.5	130	2.000	4.900
MT 214 E	1 1/4	42.0	4.05	42.1	3.5 - 4.8	165	4.550	4.150
MT 214 F	1 1/2	47.8	4.05	48.2	3.6 - 5.0	210	3.900	9.250
MT 214 G	2	59.3	4.5	60.3	3.9 - 5.5	280	10.750	14.650
MT 214 H	2 1/2	76.1	4.5	77.0	5.1 - 7.0	300	12.250	14.750
MT 214 I	3	88.9	4.8	89.9	5.5 - 7.6	400	19.900	20.350
MT 214 J	4	115.0	5.4	114.3	6.0 - 8.5	600	40.000	38.500
MT 214 K	6	168.0	5.4	168.0	7.1 - 11.0	700	54.000	58.000
MT 214 L	8	-	-	219.1	8.1 - 12.7	1100	165.000	-
MT 214 M	10	-	-	273.0	9.2 - 15.1	1365	244.000	-
MT 214 N	12	-	-	323.8	10.3 - 17.4	1620	192.000	-



# MOVEABLE STEEL GANTRY CRANE



## Feature

- » Robust light weight steel construction
- » Can go where forklift or stacker can not.
- » Heavy duty supported leg design.
- » Balanced design allows for easy maneuvering, even under load.
- » Simple belted construction.
- » Easy for assembly, disassembly and maintenance.
- » 4 casters to keep good moveability and maneuverability.
- » Patented product, all right reserved.
- » Comply with standards EN ISO12100-1:2003 & EN ISO12100-2:2003.
- » Comply with ANSI/ASME B30.17 standard.

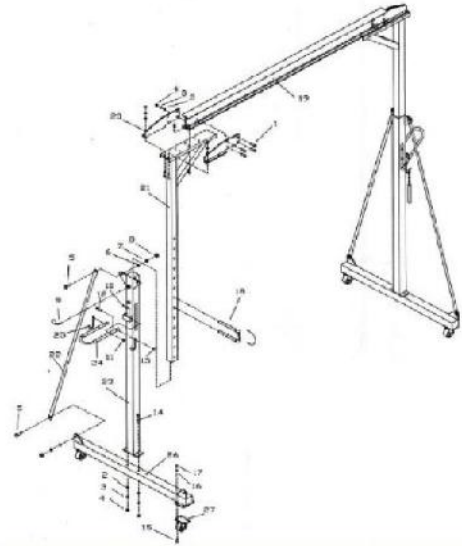

Model	Capacity		Operating height		Width between uprights		Casters		N.W.		20'fl Container (pcs)
	(kg)	(lbs)	(mm)	(feet)	(mm)	(feet)	(inch)	(q'ty)	(kg)	(lbs)	
SB0901	500	1100	2400~3600	7 7/8~11 4/5	2400	7 5/6	3.5	4	100	220	165
SB0902	1000	2200	2400~3600	7 7/8~11 4/5	2400	7 5/6	5	4	120	264	121
SB0903	1500	3300	2400~3600	7 7/8~11 4/5	2400	7 5/6	5	4	150	330	110
SB0904	2000	4400	2400~3600	7 7/8~11 4/5	2400	7 5/6	5	4	160	353	90

\* DO NOT move while loaded. \*

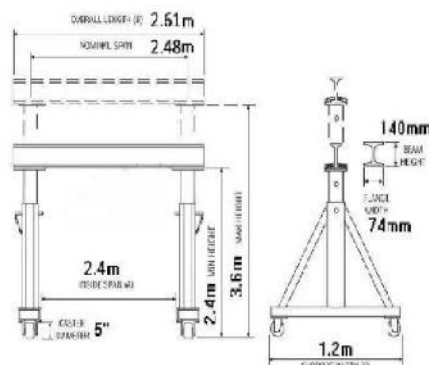



## Rescue Tripod | Safety Tripod



### Anchor points

- » **One central eye bolt:**  
Main anchor point.
- » **Three lateral eyes**  
Additional anchor points, easy to hang other safety devices.

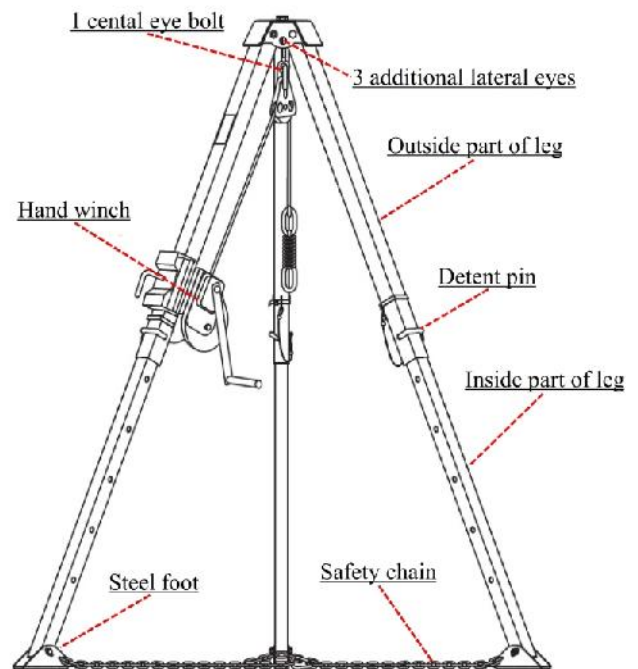

### Hand winch & connecting part

- » **Hand winch:**  
Fitted with self-lock device, equipped with 30m wire rope.
- » **Connecting part**  
Newly designed and fastened by two lock pins.

### Feature

- » The tripod is the anchorage connector for typical confined space and rescue systems.
- » It features a lightweight, high-strength aluminium construction.
- » 1 central eye bolt and 3 additional lateral eyes, easy to hang various safety devices.
- » Connecting part is fitted with safety lock pin, to keep hand winch from slipping up.
- » Telescoping legs cater to different operating heights.
- » Ring type safety chain is supplied to minimize horizontal forces and prevent the legs spreading and collapsing.
- » Steel feet incorporate a rubber sole for flat surfaces and spiked edges for slippery surfaces.
- » Equipped with hand winch c/w self-lock device.
- » Comply with Council Directive 89/686/EEC and standard EN 795.

### Technical data for tripod

- » Working load limit: 200kg.
- » Working height:
  - Legs fully extended 214cm
  - Legs fully retracted 134cm.
- » Anchor points in the head:
  - 1 main central eye bolt
  - 3 additional lateral eyes
- » Main parts: made of high strength aluminium alloy.

### For hand winch:

- » Rated capacity: 1800LBS.
- » Wire rope:
  - diameter: 4mm
  - length: 30m.
- » Gear ratio 8:1.



## Retractable Type Fall Arrester

CE

### Features

- » Designed to restrain the user from vertical falls while allowing the user to move freely.
- » High strength aluminium alloy housing, light and durable.
- » Equipped with galvanized steel cable lifeline.
- » Innovative engineering solution to arrest falls by two-disc anti-ratchet braking system.
- » Widely used in metallurgy, petroleum, automobile manufacturing, chemical industry, the electric power, bridge, aloft work..... etc.
- » Consist of snap hook connector, energy absorber, retractor, swivel safety hook and dragline.
- » Can be used in conjunction with rescue tripod and safety harness.
- » Conforms to Personal Protective Equipment Directive 89/686/EEC and standard EN360:2002.
- » Each piece with an individual certificate of declaration.

### Parameters

- » Rated capacity: 150kg.
- » About high strength steel cable:  
diameter: 4mm;  
length: available from 6m to 40m.
- » Safe stopping distance: 10cm to 20cm.

### Applications

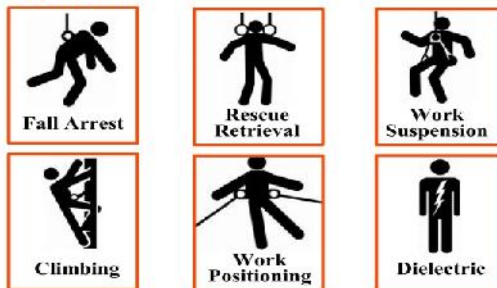

### Markings of fall arrester

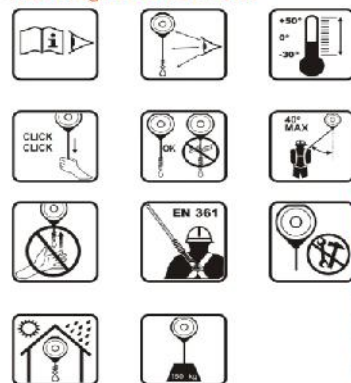

### Specifications

Model	Max. Load (kg)	Steel cable Length (m)	Diameter of steel cable (mm)
MT 6M	150	5	4
MT 10M	150	10	4
MT 15M	150	15	4
MT 20M	150	20	4
MT 30M	150	30	4
MT 40M	150	40	4

\*Overloading is strictly prohibited.\*



### MOVE IT KEVLAR 1025

Art. nr. EMBLK1025K  
Kevlar band 2,5 m  
EN 360



### MOVE IT KEVLAR 1060

Art. nr. EMBLK1060K  
Kevlar band 6 m  
EN 360





## Full Body Safety Harness

### Features

- The move it range provides a good fit and easy adjustment Options
- The Move it harness are characterized by a striking color, metal parts in one piece and strong webbing.
- Move it full body harness with twin webbing lanyard to be used With vertical anchorage system & construction industries.
- Fully adjustable shoulder and thigh straps.
- General harness with 1 D-ring on the back & 2 D-rings on the chest.
- Ideally positioned sit strap for extended comfort.
- Color: Red and Black
- EN361 / EN354 CE Approved.

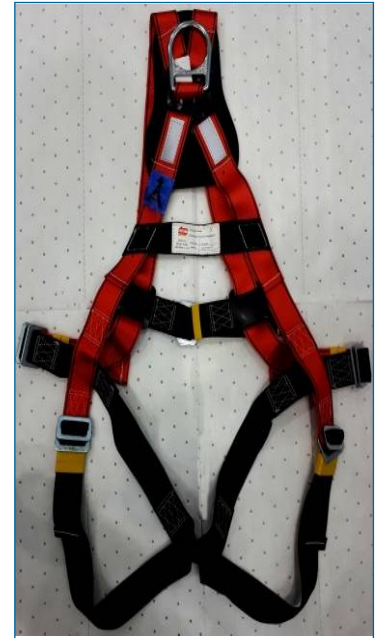

## Shock Absorber Double lanyard with Scaffolding Hook

### Features

- Polyamide Y-webbing, steel snap hook & aluminum scaffold hook.
- User for job construction, heavy industrial, logistic, Hygiene environmental, oil gas, and other activities.
- Double lanyard with two big hooks and one small snap.
- Manufactured in heavy duty polyester, 4.5 cm width by 6 ft (1.83m) length.
- The shock absorbing, is designed to limit arrest forces plus the added benefit of elasticity.
- Content type labels with the information of the product and the inspection.
- Test report with approval of international standards.



# ELECTRODE OVENS

## FEATURES AVAILABLE IN OUR ELECTRODE OVENS ARE:

1. Analogue Thermostats
2. Digital Temperature Controllers
3. Voltages offered are: 110V & 220V
4. DUAL Voltage ovens
5. Stainless steel body ovens (on request)
6. Bench oven & Flux oven models are fitted with mini-circuit breakers for safety
7. Each oven is tested and heated to rated temperature before being supplied
8. Calibration Certificates are available upon request
9. **All ovens are tested to BS 638.5 and EN 60974-1 Norms.**

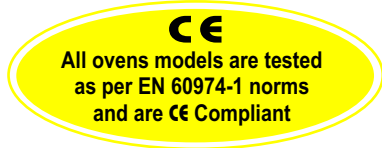

Electrode capacity	5Kg (10 Lbs)
Max. Electrode Size	18" (457mm)
Working Voltage	220 (standard)
Wattage	80watts
Supply Cable Size	18 AWG x 3 C
Temp. Range	Max. 150°C
Thermostat	None
Thermometer	None
Heating Element Type	Mica Band type
Insulation	25mm ceramic wool
Outer Size (mm)	545 x 120 x 113
Inner Chamber (mm)	Depth = 19 1/2" ø=3"
Inner Basket	Yes
Body	Pre-galvanized sheet, powder coated
Basket hook	Yes
Tilt Stand Feature	Yes
Light Indicator	Yes
Shoes	Yes
Shape	Round
Handle	Fix Handle
Wheel	None
Net Weight	4.16Kg.

## Model MT-10RiETAT



- Electrode Oven MT10
- 5kg Electrode Capacity
- Analogue Thermostat
- Temperature range : Max 150 °C

Electrode capacity	5Kg (10 Lbs)
Max. Electrode Size	18" (457mm)
Working Voltage	220 (standard)
Wattage	80watts
Supply Cable Size	18 AWG x 3 C
Temp. Range	Max. 150°C
Thermostat	None
Thermometer	None
Heating Element Type	Mica Band type
Insulation	25mm ceramic wool
Outer Size (mm)	545 x 120 x 113
Inner Chamber (mm)	Depth = 19 1/2" ø=3"
Inner Basket	Yes
Body	Pre-galvanized sheet, powder coated
Basket hook	Yes
Tilt Stand Feature	Yes
Light Indicator	Yes
Shoes	Yes
Shape	Round
Handle	Fix Handle
Wheel	None
Net Weight	4.16Kg.

## Model MT-5



- Electrode Oven MT5
- 5kg Electrode Capacity
- Temperature range : Max 150 °C

Electrode capacity	5Kg (10 Lbs)
Max. Electrode Size	18" (457mm)
Working Voltage	Dual Voltage 110 & 220V
Wattage	80watts
Supply Cable Size	18 AWG x 3 C
Temp. Range	Max. 150°C
Thermostat	None
Thermometer	None
Heating Element Type	Mica Band type
Insulation	25mm ceramic wool
Outer Size (mm)	545 x 120 x 113
Inner Chamber (mm)	Depth = 19 1/2" ø=3"
Inner Basket	Yes
Body	Pre-galvanized sheet, powder coated
Basket hook	Yes
Tilt Stand Feature	Yes
Light Indicator	Yes
Shoes	Yes
Shape	Round
Handle	Fix Handle
Wheel	None
Net Weight	4.16Kg.

## Model MT5D



- Electrode Oven MT5D
- 5kg Electrode Capacity
- Dual Voltage (110 & 220V)
- Temperature range : Max 150 °C



Electrode capacity	10Kg (10 Lbs)
Max. Electrode Size	18" (457mm)
Working Voltage	110, 220 (standard) Opt. 70V, 48V
Wattage	250watts
Supply Cable Size	18 AWG x 3 C
Temp. Range	80 - 150°C
Thermostat	Analogue
Thermometer	None
Heating Element Type	Mica Band type
Insulation	25mm ceramic wool
Outer Size (mm)	Height =590, ∅=196
Inner Chamber (mm)	Depth = 480, ∅=120
Inner Basket	Yes
Body	Pre-galvanized sheet, powder coated
Basket hook	Yes
Tilt Stand Feature	No
Light Indicator	Yes
Shoes	Yes
Shape	Square
Handle	Fix Handle
Wheel	None
Net Weight	6.00Kg.



## Model MT10

- Electrode Oven MT10
- 10Kg Electrode Capacity
- Analogue Thermostat
- Temperature range : 80-150 °C

Electrode capacity	10Kg (10 Lbs)
Max. Electrode Size	18" (457mm)
Working Voltage	Dual Voltage 110 & 220V
Wattage	250watts
Supply Cable Size	18 AWG x 3 C
Temp. Range	80 - 150°C
Thermostat	Analogue
Thermometer	None
Heating Element Type	Mica Band type
Insulation	25mm ceramic wool
Outer Size (mm)	Height =590, ∅=196
Inner Chamber (mm)	Depth = 480, ∅=120
Inner Basket	Yes
Body	Pre-galvanized sheet, powder coated
Basket hook	Yes
Tilt Stand Feature	No
Light Indicator	Yes
Shoes	Yes
Shape	Round
Handle	Fix Handle
Wheel	None
Net Weight	6.00Kg.



## Model MT10D

- Electrode Oven MT10D
- 10kg Electrode Capacity
- Analogue Thermostat
- Dual Voltage (110 & 220V)
- Temperature range : Max 150 °C

Electrode capacity	22Kg (50 Lbs)
Max. Electrode Size	18" (457mm)
Working Voltage	220V Standard
Wattage	600watts
Supply Cable Size	18 AWG x 3 C
Temp. Range	Max. 300°C
Thermostat	Analogue
Thermometer	None
Heating Element Type	Mica Band type
Insulation	2" ceramic wool
Outer Size (mm)	570 x 280 x 280
Inner Chamber (mm)	460 x 150 x 150
Inner Basket	4 sections
Body	Outer-Pre Galv. Inner Stainless Steel Sheet
Basket hook	No
Tilt Stand Feature	No
Light Indicator	Yes
Shoes	Metal Bracket
Shape	Square
Handle	Pull-Out Handle
Wheel	6" Solid Rubber
Net Weight	15.00Kg.



## Model MT22

- Electrode Oven MT22,
- 22kg Electrode Capacity,
- Analogue Thermostat,
- Temperature range : Max 300 °C
- Wheel & Handle

# BENCH OVENS

Electrode capacity	70kg (150 Lbs)
Max. Electrode Size	18" (457 mm)
Working Voltage	220 Standard
Wattage	750 Watts
Supply Cable Size	14 AWG x 3C
Temp. Range	Max. 300° C
Thermostat	Digital Temperature Control
Thermometer	Digital Temperature Control
Heating Element Type	U Shape Tubular
Thermal Insulation	2" Ceramic wool
Outer Size (mm)	L610 x W560 x H545
Inner Chamber (mm)	L500 x W245 x H270
Inner Basket	2 Sections
Body	Pre Galv. Steel Sheet, powder Coted
Light Indicator	Yes
Shoes	Metal
Shape	square
Net Weight	39.20 kg
Shipping Dimension	27 3/4 x 24 1/2 x 28 1/4
Shipping Weight	53.0 Kg

**Model MT70**



- Bench Oven 70kg Capacity • Digital Temperature Controller
- Temperature range : Max 300° C

PARAMETERS	MT-100	MT-200	MT-300
Electrode capacity	100kg	200kg	300kg
Max. Electrode Size	18" (457 mm)	18" (457 mm)	18" (457 mm)
Working Voltage	220V	220V	220V
Hz	60Hz	60Hz	60Hz
Wattage	1500 watts	3000 watts	3500 watts
Supply Cable Size	14AWG x 3C	2.5mm2 x 3C	2.5mm2 x 3C
Temp. Range	Max. 400° C	Max. 500° C	Max. 500° C
Thermostat	Digital Temperature Control	Digital Temperature Control	Digital Temperature Control
Thermometer	Digital Temperature Control	Digital Temperature Control	Digital Temperature Control
Heating Element Type	U Shape Tubular	U Shape Tubular	U Shape Tubular
Thermal Insulation	3" Ceramic wool	3" Ceramic wool	3" Ceramic wool
Outer Size (mm)	L610 x W665 x H595	L610 x W705 x H735	L620 x W735 x H960
Inner Chamber (mm)	L500 x W350 x H320	L520 x W430 x H420	L515 x W420 x H715
Inner Basket	2 Sections	4 Sections	3 Sections
Body	Outer Pre Galv. Steel Sheet, powder Coted Inner S/Steel Sheet	Outer Pre Galv. Steel Sheet, powder Coted Inner S/Steel Sheet	Outer Pre Galv. Steel Sheet, powder Coted Inner S/Steel Sheet
Light Indicator	Yes	Yes	Yes
Shoes	Metal	Metal	Metal
Shape	square	square	square
Net Weight	48.0 kg	81.5 kg	95.6 kg
Shipping Dimension	L27 3/4 x W28 1/2 x H30 1/4 "	L27 1/2 x W30 x H34 3/4"	L27 1/4 x W31 x H39"
Shipping Weight	63.0 Kg	103.0 Kg	115.0 Kg



# FLUX OVENS

Electrode capacity	100 Ltr.
Max. Electrode Size	.....
Working Voltage	220 (Standard)
Wattage	3000 Watts
Supply Cable Size	2.5mm2 x 3C
Temp. Range	Max300° C
Thermostat	Digital Temperature Controller
Thermometer	Digital Temperature Controller
Heating Element Type	Tubular
Thermal Insulation	3" Ceramic Wool
Outer Size (mm)	L864 x W610 x H1180
Inner Chamber (mm)	100 Ltr. Capacity
Inner Basket	None
Body	Outer Pre Galv. Steel sheet, powder, Inner S-Steel
Air blower	None
Light Indicator	Yes
Shoes	Metal
Shape	Square
Net Weight	78.6 kg
Shipping Dimension	L37 x W26 1/2 x H53"
Shipping Weight	98.0 kg

**Model MT FLUX 100**



- Flux Oven 100 Ltr Capacity
- with digital temp. Controller
- Temperature range : 300° C





# Industrial & Institutional Strength Products



## SIMPLE GREEN Industrial Cleaner & Degreaser



- Cleans, degreases & deodorizes all washable surfaces
- **EPA Safer Choice product**, meets LEED cleaning policies
- Non-toxic and biodegradable formula
- Non-flammable, non-abrasive and non-corrosive
- Removes grime on equipment, engines and machinery
- Ideal for janitorial cleaning and building maintenance
- Cleans and deodorizes food residue, oils and grease
- Perfect for surface-prep prior to painting and plating
- Safe for use in cleaning equipment and parts washers

	24 oz	1 gal	2.5 gal	5 gal	15 gal	55 gal	275 gal
Original Scent	2710001213012	2710200613005	2710000213225	2700000113006	2700000113016	2700000113008	2700000113275
Lemon Scent	3010001214002	3010200614010	-	3000000114005	-	3000000114055	3000000114275



## EXTREME SIMPLE GREEN® Aircraft & Precision Cleaner



- High soil capacity, superior grease cutting and clean rinsing formula ensures fast and effective cleaning
- No reagents that oxidize finishes or degrade plastics
- Biodegradable and petroleum-distillate free
- Use on structural metals, hoses, seals and factory finishes without risk of hydrogen embrittlement or corrosion
- Ideal for MRO, manufacturing and surface prep
- Safe for entrance into oil/water separators and clarifiers
- Meets a variety of aircraft testing specifications

	32 oz	1 gal	5 gal	55 gal	275 gal
	0110001213412	0110000413406	0100000113405	0100000113455	0100000113475



## CRYSTAL SIMPLE GREEN® Industrial Cleaner & Degreaser



- Powerful cleaning with no added color or scent
- Non-toxic and biodegradable formula
- **NSF registered A1, A2, A4, A8, B1 and C1**
- Non-corrosive, non-abrasive and clean rinsing
- Use in all food processing facility areas including on cooking equipment, floors, walls, utensils and laundry
- Cuts through grease on equipment, machinery and parts
- Ideal for manufacturing, cosmetic and medical industries
- Use in floor scrubbers, carpet extractors and dip tanks

	24 oz	1 gal	5 gal	15 gal	55 gal	275 gal
	0610001219024	0610000619128	0600000119005	0600000119015	0600000119055	0600000119275



## FOAMING CRYSTAL SIMPLE GREEN® Industrial Cleaner & Degreaser



- Foam clings to vertical and hard-to-reach spaces
- Non-toxic and biodegradable formula
- **NSF registered A1, A4, A8 and C1**
- Non-corrosive, non-abrasive and non-flammable fluid
- Cuts through thick grease, carbon and baked-on soils
- Removes metal working fluids, hydraulic fluids and oils
- Safe for metals, finishes, plastics, rubbers and more
- Clean rinsing formula is ideal for manufacturing, cosmetic, medical and food processing industries

	20 oz
	0610001219010



Keeping Your Environment Cleaner and Safer

**simple  
green**



**SIMPLE GREEN SAFETY TOWELS®**



- Larger-sized wipes for heavy cleaning and degreasing
- Uses powerful, yet non-toxic Crystal Simple Green®
- Dual-sided for non-abrasive scrubbing and easy shining
- **NSF registered A1, A4, A8 and C1**
- Removes tough soils like grease, oil, wet paint and tar
- Safe for use on metals, concrete, rubber, finished wood, tile, stone, porcelain, carpets and more
- Excellent wicking and fluid capacity for liquid spills
- Ideal for use where access to water is limited

5 count	75 count
3810005013322	3810000613351



**SIMPLE GREEN CLEAN FINISH® Disinfectant Cleaner**



- Ready-to-use cleaner, disinfectant & deodorizer
- Disinfects up to 20x faster than popular brands
- Kills 99.9% of bacteria in just 5 seconds
- Kills cold and flu viruses
- EPA registered, **broad-spectrum** and bloodborne pathogen compliant
- Alcohol, solvent & bleach-free formula
- Eliminates stubborn stains & tough soils
- For use on hard, non-porous surfaces

32 oz	1 gal	5 gal	55 gal
2810001201032	2810000401128	2800000100005	2800000100055



**SIMPLE GREEN D PRO 3 Plus™ Antibacterial Cleaner**



- Kills 2 times more pathogens than the competition
- EPA registered bactericide, virucide, fungicide and mildewstat for hard, non-porous surfaces
- **Hospital-grade formula** eliminates an extensive list of over 75 pathogens including antibiotic resistant "superbugs"
- Broad-spectrum formula, bloodborne pathogen compliant
- Non-acidic formula will not harm tile or sealed stone and grout
- Controls mold and mildew, deodorizes tough odors

1 gal	5 gal	55 gal
3310200601001	3300000101005	3300000101055



**SIMPLE GREEN D PRO 5® One-Step Disinfectant**



- Highly versatile concentrate is a disinfectant, cleaner, sanitizer, fungicide, mildewstat, virucide and deodorizer
- U.S. EPA registered, **hospital-grade formula**
- Blood-borne pathogen compliant
- No added color or scent makes it ideal for use in food production, food processing and commercial kitchens
- Sanitizes hard, non-porous food contact surfaces
- Disinfects and inhibits mold growth in locker rooms
- Eliminates Canine Distemper Virus and Feline Calicivirus

1 gal	5 gal	55 gal
3410000430501	3400000130505	3400000130555





# Industrial & Institutional Strength Products



## SIMPLE GREEN CLEAN BUILDING® All-Purpose Cleaner Concentrate



- Cleans dirt, grime, and oily soils without heavy scrubbing
- Meets Green Seal™ GS-37 and LEED building standards
- Non-toxic and biodegradable formula
- Non-caustic and non-flammable
- For use on all washable surfaces
- Spray, wipe and mop applications
- Cleans metals, plastics, stone, sealed wood, painted surfaces, concrete, vinyl, and more
- Rinses cleanly without smudging or streaking

1 gal  
1210000211001



## SIMPLE GREEN CLEAN BUILDING Bathroom Cleaner Concentrate



- Removes dirt, grime, scale, scum and hard water marks
- Meets Green Seal™ GS-37 and LEED building standards
- Non-toxic and biodegradable formula
- Non-caustic and non-flammable
- Use in bathrooms, locker rooms, saunas, steam rooms, spas and beauty facilities
- Safe for washable hard surfaces such as ceramic tile, glazed tile, Corian®, Formica®, grout, faucets, fixtures, porcelain, and cured fiberglass

1 gal  
1210000211101



## SIMPLE GREEN CLEAN BUILDING Glass Cleaner Concentrate



- Provides a streak-free shine for glass and mirrors
- Meets Green Seal™ GS-37 and LEED building standards
- Non-toxic and biodegradable formula
- Non-caustic and non-flammable
- Strong wetting agents lift soils without leaving behind soapy residues
- Restores shine and clarity to glass, mirrors and other reflective surfaces
- Safe for use on plastics

1 gal  
1210000211301



## SIMPLE GREEN CLEAN BUILDING Carpet Cleaner Concentrate



- Cleans and removes stains from carpets and upholstery
- Carpet and Rug Institute certified not to harm backings or degrade fibers
- Meets Green Seal™ GS-37 and LEED building standards
- For pre-spray and extraction cleaning
- Use on carpets, rugs and fabric upholstery
- Residue-free cleaning with no added color or scent
- Non-toxic and biodegradable formula
- Non-caustic and non-flammable

1 gal  
1210000211201

Keeping Your Environment Cleaner and Safer

**simple  
green**



**SIMPLE GREEN LIME SCALE REMOVER**



- Non-abrasive, organic salt formula is bleach, ammonia and phosphorous free
- Won't strip protective finishes, cause damage or discoloration or etch sensitive surfaces
- Descales HVAC components, pipes, hoses, tanks, storage systems, washing machines and more
- Eliminates mineral deposits and soap scum from sinks, toilets, spigots, sprinklers, lighting, glass and furniture
- Safe for ABS, PVC, copper and other plumbing materials

32 oz	1 gal	5 gal	55 gal
1710001250032	1710000650128	1700000150005	1700000150155



**SIMPLE GREEN FOAMING COIL CLEANER**

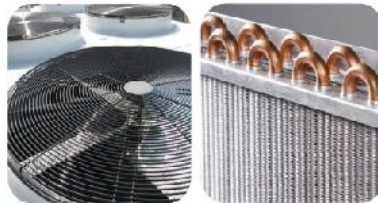

- Aerosol enables versatile 360 degree precise application
- Self-rinsing on condensate producing coils
- **NSF registered C1 & P1** for use in food processing areas
- Non-corrosive, non-fuming and non-flammable formula
- Safe for aluminum, stainless steel, painted or enameled metals, plastics, acrylic, stone and more
- Ideal for use on HVAC units, refrigerators & freezers
- Quickly cleans coils, fan blades, blowers, grills, registers, heat exchangers, vents, electronic filters & drain pans

20 oz Aerosol	1 gal	5 gal	55 gal
0110001213418	0110000404001	0100000104005	0100000104055



**SIMPLE GREEN ANTI-SPATTER**



- High-performance spatter release solution
- Non-corrosive formula with no added color or scent
- Free of solvents, methylene chloride and silicone
- Rinses residue free for use prior to plating or painting
- Safe for aluminum, steel and other metal surfaces
- Keeps nozzles, diffusers, tips and shrouds free of build-up
- Protects vices, pliers and other tools from damage
- Ready-to-use formula goes on easily and quickly
- Reduces costly downtime for spatter removal

32 oz	1 gal	5 gal	55 gal
1410001213452	1410000413454	1400000113457	1400000113467



**SIMPLE GREEN RIG WASH**



- Removes grease, oil and drill muds without harsh solvents
- Biodegradable formula with no added color or scent
- Non-abrasive, non-corrosive and non-flammable formula
- Safe for entry into oil/water separators and clarifiers
- Ideal for on and off-shore drilling rigs and equipment
- Cleans built-up residue from pumps, jacks and pads
- Use on platforms, decks, derricks, liners, casings, crown and traveling blocks, and blowout preventers
- Cleans equipment, engines, generators and vehicles

1 gal	5 gal	55 gal
0110000403001	0100000103005	0100000103055





# Industrial & Institutional Strength Products



## SIMPLE GREEN CARPET CLEANER



- Professional-strength cleaning and deodorizing
- Proven safe and effective by the Carpet and Rug Institute
- Non-toxic, biodegradable and petroleum-distillate free
- Will not harm carpet fibers or backings
- Removes grease, oil, coffee, wine, blood and more
- Ideal for spot cleaning rugs and fabric upholstery
- Use in hot water extraction and steam carpet machines
- Special protection agent maintains the stain resistance already found in most carpets, rugs and upholstery

1 gal  
0510000615128



## SIMPLE GREEN HAND CLEANER GEL



- Heavy-duty hand cleaning free of d'Limonene
- Utilizes natural pumice to remove dirt and grease
- Contains lanolin to soothe, protect and moisturize skin
- Free of ammonia which can irritate cuts and abrasions
- Removes brake dust, transmission fluid and motor oil
- Cleans wet paint, inks, adhesives, tar, soot and carbon
- Deodorizes stubborn and lingering smells
- Does not require water or rinsing
- Leaves behind no greasy film, sticky residue or dry feel

5 oz      1 gal  
0910201242150      0910200442128



## SIMPLE GREEN STONE CLEANER



- Cleans natural, synthetic and engineered stone
- Non-toxic and non-abrasive formula
- No rinsing required
- Dries smudge and streak free
- Cleans natural stone such as granite, travertine, limestone, marble, soap stone and slate
- Shines synthetic stone such as quartz, ceramic, porcelain, terrazzo, Corian® and Silestone®
- Non-toxic formula is safer for kitchens and bathrooms

32 oz  
3710001218401



## SIMPLE GREEN STONE POLISH



- Polishes natural, synthetic and engineered stone
- Non-toxic and non-abrasive formula
- No rinsing or waiting required
- No dulling build up
- Restores luster to natural stone such as granite, travertine, limestone, marble, soap stone and slate
- Protects synthetic stone such as quartz, ceramic, porcelain, terrazzo, Corian® and Silestone®
- Non-toxic formula is safer for kitchens and bathrooms

32 oz  
3710001218402



# Industrial & Institutional Strength Products



### SIMPLE GREEN 80 Gallon Parts Washer



- Corrosion-free, stainless steel construction
- Preset 120 PSI filter regulator with auto drain
- Adjustable agitation speed
- Spring-loaded door closure with a 165°F fusible link
- Flow-through brush system for touch up precision cleaning
- Heavy duty industrial grade pump
- 80 gallon max. fluid level
- 250 lb. load capacity

80 gal Parts Washer (115V) 0800000179180	80 gal Parts Washer (230V) 0800000179181
---	---



### SIMPLE GREEN 60 Gallon Parts Washer



- Made of industrial-grade polyethylene plastic
- Stainless steel work shelf, flexible Loc-Line® nozzle and flow-through brush with polyester filaments
- Separate heater and pump switches with on/off indicators
- 105°F fixed thermostat for optimal cleaning
- Ground Fault Circuit Interrupter (GFCI) protected
- 60 gallon max. fluid level and 200 lb. load capacity

60 gal Parts Washer (115V) 0800000179260	60 gal Parts Washer (230V) 0800000179261
---	---



### SIMPLE GREEN 30 Gallon Parts Washer



- Made of industrial-grade polyethylene plastic
- Stainless steel work shelf, flexible Loc-Line® nozzle and flow-through brush with polyester filaments
- Clean out plug for easy draining and filter attachment
- Separate heater and pump switches with on/off indicators
- 105°F fixed thermostat for optimal cleaning
- Ground Fault Circuit Interrupter (GFCI) protected
- 19-25 gallon capacity for effective cleaning

30 gal Parts Washer (115V) 0800000179130	30 gal Parts Washer (230V) 0800000179131
---	---



### SIMPLE GREEN 4 + 1 Select Proportioner



- Dispenses 5 concentrates or water at up to 5 dilution ratios
- 4 low (1GPM) bottle fill and 1 high (3.5GPM) bucket fill outputs
- Accurate dilution regardless of water pressure fluctuation
- E-Gap educator elastomeric sleeve provides backflow protection
- American Society of Safety Engineers (ASSE) 1055 Approved
- Includes tips for 1:2, 6:1, 4:7 set dilution ratios, one customizable tip, and 4 foot bucket-fill hose with storage hook
- Expansive workspace inside the unit for plumbing and pick up tubing and easy, tool-free maintenance

4 + 1 Select Proportioner 0800000108950
--

### Simple Green® 3 Gallon Pump Up Foamer Pro



Portable foam applicator with the familiar ease and portability of a typical pump-up sprayer. Heavy-duty, easy-grip trigger gun with 10" extension wand and locking latch. 6' hose with a wide pattern stainless steel fan nozzle. Viton/Nitrile internal seals and o-rings provide resistance to acidic chemicals. HDPE tank with UV inhibitor can withstand chemical temperatures up to 120°F. Durable manual pump can create up to 45 PSI. Holds 3 gallon of concentrate.

3 U.S. Gallon



### SIMPLE GREEN Dilution Bottle



- Sturdy high-density polyethylene (HDPE) plastic bottles can withstand repeated, heavy use
- Pre-measured levels allow accurate dilution and optimum cleaning performance for Simple Green cleaning and degreasing products
- Dual-action spray and foam trigger for large scale, vertical or precision applications
- 32 oz. liquid capacity
- 8 bottles per case

22 oz. 080000013221
------------------------



### SIMPLE GREEN Multi-Dilution Foamer



- Ice-cold-cooled inserts provide a 1:2 - 1:28 dilution "spitting" range
- Produces thick, clinging foam that increases product contact time and enhances cleaning performance
- Provides powerful jet-spray or precision stream
- Convenient hard-lock for continuous operation
- Easy-lose-and-attachment, provides quick removal from cleaning area without mixing
- 96 oz. injection molded concentrate container

Multi-Dilution Foamer 080000013292
---------------------------------------





The UK's leading infection control brand now in GCC countries

## DISCOVER THE BIOGUARD DIFFERENCE

Hygiene, Cleaning and Infection Control



### DISINFECTANT CLEANING SOLUTION

A medical grade alcohol free disinfectant and cleaning solution that is truly effective across all professional healthcare environments. Available as a full sized spray or smaller sprays for 'on the go' hygiene.

#### SUITABLE FOR USE ON:

- Work surfaces, floors and walls
- Fabric and furnishings
- Laminar air flow & incubators
- Equipment and utensils
- Fogging Solution providing whole room decontamination

### FOAM HAND SANITISER

Alcohol free Foam Hand Sanitiser that cleans hands without the need for water. Independently tested to BSEN1276 standard and suitable for use on hands and body, making it ideal for bed baths.

#### SUITABLE FOR USE ON:

- Hands - No water needed
- Body - No water needed



### HAND & SURFACE WIPES

A medical grade hand and surface wipe system which cleans and protects and is independently tested. Available as alcohol wipes or alcohol free wipes which have no compromise on performance.

#### SUITABLE FOR USE ON:

- Hands and body
- Work surfaces, floors and walls
- Fabric and furnishings
- Equipment and utensils
- Medical equipment, ultra sound supplies and rental
- Probes
- Laminar Airflow benches & Incubators

### GEL HAND SANITISER

Medical grade Gel Hand Sanitiser with alcohol that cleans and disinfects hands without the need for water. Independently tested to BSEN1276 standard.

#### SUITABLE FOR USE ON:

- Hands - No water needed

**DISCOVER THE DIFFERENCE WITH OUR RANGE OF SUPERIOR HYGIENE, CLEANING & INFECTION CONTROL**



**MEDICAL HAND SCRUB**

Medical grade, alcohol free, antiviral and bacterial hand scrub for high risk environments. Contains plant based moisturisers to reduce the risk of skin irritation compared with other products.

**SUITABLE FOR USE ON:**

- Hands
- OT, ICU or in high risk environments

**DISINFECTANT AIR FRESHENER**

Our 2 in 1 air freshener and disinfectant eliminates all hygiene risks and unpleasant odours. Ideal in environments where the risk of harmful air borne organisms are present, such as consulting room, ambulances and reception areas.

**SUITABLE FOR USE ON:**

- Surfaces
- Fabric and furnishings



**ABSORB POWDER**

Our medical grade Absorb Powder can be used across a whole spectrum of body fluid and chemical spillages. This product is designed to be used in any environment where you need to quickly, hygienically, and safely clean up fluids.

**SUITABLE FOR USE ON:**

- Work surfaces and floors
- Fabric and furnishings



**PUREHOLD HYGIENE HANDLE PRO**

Developed in conjunction with NHS Infection Prevention Specialists, the innovative new Pure Hold Hygiene Handle offers an effective solution to the problem of widespread non-compliance with hand hygiene standards.

**PUREHOLD ECO HANDLE & PUSH PLATE**

Embedded silver ion technology in these easy to fit door handles ensures your doors can be germ free 24/7 breaking the chain of infection and significantly reducing cross infection.

**SUITABLE FOR USE ON:**

- OT, ICU or any high risk environment
- Any door where you need to reduce infection risk





## SILVER OIL ONLY PADS

Dimpled Meltblown Pads

### FEATURES & BENEFITS:

- Highly Adsorbent Meltblown Polypropylene for Cost-Effectiveness
- Adsorbs Petroleum Based Liquids and Repels Water
- Cost Effective Solution to Cleaning Up Oil Spills, Leaks and Drips
- Performances Minimize Waste
- Packed in a Sturdy Dispenser Box for Easy Handling
- Dimples Add Strength
- Available in Three Different Basis Weights for Added Choice
- Available in Jumbo Sized Pad for Greater Coverage



## BRONZE OIL ONLY PADS

Plain Oil Only Pads

### FEATURES & BENEFITS:

- Extremely Adsorbent Meltblown Polypropylene for Cost-Effectiveness
- Our Most Economical Range of Sorbent Pads
- Adsorbs Petroleum Based Liquids and Repels Water
- Cost Effective Solution to Cleaning Up Oil Spills, Leaks and Drips
- Ideal for Use During Marine Spills
- Packaged in a Plastic Bag for Cost Effectiveness



Part #	Description	Packing	Absorption Cap. (L)
OSW-75	Perforated Heavy weight : Pads	40cm x 50 cm (100/dispense box)	121

Part #	Description	Packing	Absorption Cap. (L)
OBW-70	Light weight Pads	40cm x 50 cm (200/bale)	130



## BRONZE OIL ONLY ROLLS

Plain Oil Only Rolls

- Extremely Adsorbent Meltblown Polypropylene for Cost-Effectiveness
- Our Most Economical Range of Sorbent Rolls
- Adsorbs Petroleum Based Liquids and Repels Water
- Cost Effective Solution to Cleaning Up Oil Spills, Leaks and Drips
- Ideal for Use During Marine Spills
- Packaged in a Plastic Bag for Cost Effectiveness
- No Dimples Give You Our Most Adsorbent Rolls



## OIL ONLY SOCKS

### FEATURES & BENEFITS:

- Filled with 100% Polypropylene for Cost-Effectiveness
- Flexible – Can Therefore be Shaped Around Leaky Machinery or Drums
- Available in Two Different Lengths for Added Customer Choice
- Can Also be Used During Clean-Up of Smaller Oil Spills on Water
- Ideal for Use in Order to Surround and Contain Liquids During a Land Spill
- Adsorbs Petroleum Based Liquids and Repels Water



Part #	Description	Packing	Absorption Cap. (L)
OBW-91	Heavy weight Rolls	41cm x 46 m (2/bag)	292

Part #	Description	Packing	Absorption Cap. (L)
OSW-34	7.6X122cm Socks	40 Socks/box	220
OSW-37	7.6X305cm Socks	6 Socks/box	84



## OIL ONLY BOOMS



Spilfyter offers a complete range of marine oil only sorbents. Products available include booms. These booms are ideal for use when cleaning up oil spills/ leaks on water. Spilfyter marine sorbents can be used in harbors/ports, on rivers, lakes and for many other marine applications. Silver Booms provide a high retention of oil during clean-up of spills.

Part #	Description	Packing	Absorption Capacity (L)
OSW51S	Silver 20 cm x 3 Meter Booms	4/bag	269



## OIL ONLY PILLOWS

### PILLOWS

- Filled with 100% Polypropylene for Cost-Effectiveness
- Ideal for Soaking Up Larger Spills Concentrated to One Specific Area
- Available in Three Different Sizes for Added Flexibility
- Can Also Be Used During Clean-Up of Smaller Oil Spills on Water
- Ideal for Putting Under Leaky Pipes, Gaskets or Other Leaking Equipment
- Adsorbs Petroleum Based Liquids and Repels Water



Part #	Description	Packing	Absorption Cap. (L)
OSW-61	25 x 25 cm Pillow	20 Pillows /box	57



## SILVER MAINTENANCE PADS

Dimpled Meltblown Pads

### FEATURES & BENEFITS:

- Highly Adsorbent Meltblown Polypropylene for Cost-Effectiveness
- Pads are Static Resistant Giving Greater Safety When Handling Flammable Liquids
- Adsorbs Most Industrial Liquids (Oil-Based as well as Water Based)
- Cost Effective Solution to Cleaning Up Oil Spills, Leaks and Drips
- Perforations Minimize Waste
- Packed in a Sturdy Dispenser Box for Easy Handling



Part #	Description	Packing	Absorption Cap. (L)
USG-75	Perforated Heavy Weight Pads	41 cm x 46 cm (100/dispenser box)	91



## SILVER MAINTENANCE ROLLS

Dimpled Meltblown Rolls

### FEATURES & BENEFITS:

- Highly Adsorbent Meltblown Polypropylene for Cost-Effectiveness
- Rolls are Static Resistant Giving Greater Safety When Handling Flammable Liquids
- Adsorbs Most Industrial Liquids (Oil-Based as well as Water Based)
- Cost Effective Solution to Cleaning Up Oil Spills, Leaks and Drips
- All Rolls are Perforated Down Center as well as Across the Width thus Minimizing Waste
- Packed in a Plastic Bag for Greater Economy



Part #	Description	Packing	Absorption Cap. (L)
USG-91	Perforated Heavy Weight Rolls	41 cm x 46 m (2/bag)	182



## MAINTENANCE SOCKS

- Filled with Polypropylene for Cost-Effectiveness
- Flexible – Can Therefore be Shaped Around Leaky Machinery or Drums
- Available in Two Different Lengths for Added Customer Choice
- Ideal for Use in Order to Surround and Contain Liquids During a Land Spill
- Adsorbs Petroleum Based as well as Water Based Liquids
- Can be Used as Temporary Containment During a Spill Situation



Part #	Description	Packing	Absorption Cap. (L)
USG-30	7,6 x 122 cm Socks	15 socks/box	85
USG-34	7,6 x 122 cm Socks	40 socks/box	220

## MAINTENANCE PILLOWS

### FEATURES & BENEFITS:

#### PILLOWS

- Filled with Polypropylene for Cost-Effectiveness
- Ideal for Soaking up Larger Spills Concentrated to One Specific Area
- Available in Three Different Sizes for Added Flexibility
- Adsorbs Most Industrial Liquids (Oil-Based as well as Water Based)
- Ideal for Putting Under Leaky Pipes, Gaskets or Other Leaking Equipment



Part #	Description	Packing	Absorption Cap. (L)
USG-61	25 cm x 25 cm Pillows	20 pillows/Box	57





## SILVER CHEMICAL/HAZMAT PADS

Dimpled Meltblown Pads

### FEATURES & BENEFITS:

- Highly Adsorbent Meltblown Polypropylene for Cost-Effectiveness
- Designed to Adsorb Chemicals and Other Hazardous Liquids
- Ideal for Use in Laboratories, Hospitals and Chemical Storage Areas
- Perforations Minimize Waste
- Packed in a Sturdy Dispenser Box for Easy Handling
- Available in Two Different Basis Weights for Added Choice
- Yellow Color Stands Out During a Spill Therefore Providing a "CAUTION" Warning
- Pads are Static Resistant Giving Greater Safety When Handling Flammable Liquids



Part #	Description	Packing	Absorption Cap. (L)
S2-75	Perforated Heavy Weight Pads	41 cm x 46 cm (100/dispenser box)	97



## SILVER CHEMICAL/HAZMAT ROLLS

Dimpled Meltblown Rolls

### FEATURES & BENEFITS:

- Highly Adsorbent Meltblown Polypropylene for Cost-Effectiveness
- Designed to Adsorb Chemicals and Other Hazardous Liquids
- Ideal for Use in Laboratories, Hospitals and Chemical Storage Areas
- Rolls are Perforated Down Center as well as Across the Width Creating Cost Savings
- Packed in a Sturdy Box for Easy Handling (41 cm Wide Rolls are in Dispenser Box)
- Yellow Color Stands Out During a Spill Therefore Providing a "CAUTION" Warning
- Rolls are Static Resistant Giving Greater Safety When Handling Flammable Liquids



Part #	Description	Packing	Absorption Cap. (L)
HGY-91	Perforated Heavy Weight Pads	41 cm x 46 m (2/ box)	94



## CHEMICAL/HAZMAT SOCKS

### FEATURES & BENEFITS:

- Filled with 100% Meltblown Polypropylene for Cost-Effectiveness
- Flexible – Can Therefore be Shaped Around Leaky Machinery or Drums
- Available in Two Different Lengths for Added Customer Choice
- Ideal for Use in Order to Surround and Contain Liquids During a Land Spill
- Designed to Prevent Flow as well as Adsorb Chemicals and Other Hazardous Liquids



Part #	Description	Packing	Absorption Cap. (L)
S2-34	7,6 X 122 cm Socks	40 socks / box	220

## CHEMICAL / HAZMAT PILLOWS

### FEATURES & BENEFITS:

#### PILLOWS

- Filled with Polypropylene for Cost-Effectiveness
- Ideal for Soaking up Larger Spills Concentrated to One Specific Area
- Available in Three Different Sizes for Added Flexibility
- Ideal for Use With Chemicals and Other Aggressive Liquids
- Ideal for Putting Under Leaky Pipes, Gaskets or Other Leaking Equipment



Part #	Description	Packing	Absorption Cap. (L)
S2-62	46cm x 46cm Pillow	10 Pillows / box	78



Description	Part # Hazmat	Part # Oil Only	Part # Maintenance
Economy Truk-Kit	OSK-TE (21 L)	MSK-TE (19 L)	HSK-TE (19 L)
Standard Truk-Kit	OSK-TS (36 L)	MSK-TS (34 L)	HSK-TS (34 L)
Large Truk-Kit	OSK-TL (84 L)	MSK-TL (79 L)	HSK-TL (65 L)
Grab & Go Spill Kit	OSK-GG (26 L)	MSK-GG (25 L)	HSK-GG (25 L)
20 Gallon Drum Kit	OSK-20 (68 L)	MSK-20 (61 L)	HSK-20 (60 L)
55 Gallon Overpack Kit	OSK-55 (179 L)	MSK-55 (167 L)	HSK-55 (165 L)
95 Gallon Overpack Kit	OSK 95 (358 L)	MSK-95 (340 L)	HSK-95 (337 L)
Spill Kaddie	OSK-KA (95 L)	MSK-KA (83 L)	HSK-KA (86 L)
120 L Wheelie Bin Spill Kit	OSK-120 (171 L)	MSK-120 (158 L)	HSK-120 (161 L)
240 L Wheelie Bin Spill Kit	OSK-240 (335 L)	MSK-240 (283 L)	HSK-240 (292 L)
360 L Wheelie Bin Spill Kit	OSK-360 (448 L)	MSK-360 (398 L)	HSK-360 (410 L)
Large Spill Cart	OSK-SC (798 L)	MSK-SC (774 L)	HSK-SC (770 L)

Note: Adsorption Capacity Indicated in Brackets Next to Each Part #

Compact Acid/Base Combo Spill Kit	270002
Large Acid/Base Combo Spill Kit	270001
Liquid Formula Acid Spill Kit	405104
Dry Formula Acid Spill Kit	270005
Liquid Formula Base Spill Kit	405304
Dry Formula Base Spill Kit	270006



# RUST REMOVER

The *easy* metal restorer  
that's *easy* on your skin!



- Non-toxic
- No Fumes
- Biodegradable
- Environmentally Safe
- Eliminates rust effortlessly in minutes

An R&D Magazine  
Top 100 invention!

- 
- Removes rust quickly without scrubbing
  - No fumes or bad odors
  - Non-toxic
  - Non-corrosive
  - Safe on skin
  - Non-flammable
  - No VOC's
  - Water soluble
  - Biodegradable
  - Contains no acids, bases or solvents
  - Will not harm un-rusted steel
  - Safe disposal in sewer
  - An excellent rust inhibitor
  - Safe on other metals
- 

EVAPO-RUST™ is so effective, it's currently being used by the U.S. Army's 4th Infantry Division in Fort Hood, Texas for maintenance of the M1A1 Abrams Battle Tank.

HARRIS INTERNATIONAL LABORATORIES, Inc.  
2078 Ford Avenue, Springdale, AR 72764  
PO Box 6487, Springdale, AR 72766  
TEL: 888-329-9877 / 479-756-9877  
FAX: 479-927-3202  
info@evapo-rust.com  
www.evapo-rust.com



*"It's quick simple, and unlike some other products, is non-toxic. Busting rust was never easier!"*

-Street Rodder Magazine

A product of extensive research, EVAPO-RUST™ rust remover is an environmentally safe water based product that has been proven to make even deep rust disappear in minutes, without any scrubbing.

It's so easy to use, anyone can restore their rusted tools, auto parts, even firearms to like-new condition. One gallon de-rusts up to 300 pounds of steel.



EVAPO-RUST™ will not harm metals, rubber, plastic, PVC, Viton, most paints, or un-rusted steel. In fact, immersing un-rusted objects in EVAPO-RUST™ provides excellent long-term rust protection.

Best of all, EVAPO-RUST™ is safe to use. It's non toxic, non corrosive, non flammable, and contains no acids, alkalis or petroleum solvents. EVAPO RUST™ is also biodegradable.

## Rust removal has never been easier!

1. **POUR** into a container a sufficient amount of EVAPO-RUST™ to completely cover the rusted object.
2. **IMMERSE** the rusted object into the EVAPO-RUST™ solution for 30 minutes (light rust) up to overnight (heavy rust).
3. **RINSE** item with water. If deep rust remains in pits, re-immerses in EVAPO-RUST™.

### How does EVAPO-RUST™ work?

EVAPO-RUST™ uses "selective chelation," a process in which a large synthetic molecule forms a bond with metals and holds them in solution. The active ingredient in EVAPO-RUST™ bonds exclusively to the iron in iron oxide - not in steel.

### Do parts have to be completely clean before treatment?

No. EVAPO-RUST™ contains detergents which can penetrate dirt and oil. Still, surface contaminants can slow the process and shorten the life of EVAPO-RUST™. Heavy greases and cosmoline should be removed prior to de-rusting.

### Will EVAPO-RUST™ remove bluing and other oxide finishes?

Yes. In about 30 minutes. Anodizing will not be removed. Powder coating and paints that do not contain oxides won't be removed.

### Can I clean brass, copper and aluminum with EVAPO-RUST™?

No, it will not clean (or damage) any of these metals. It will not harm plastic, clothing or glass either.

### I get a black film on some parts after using EVAPO-RUST™. What is it and how do I remove it?

High carbon steel and tool alloy steel items will have a darker appearance when de-rusted. This dark film is carbon, and can be easily wiped off with a cloth.

### Can I de-rust by spraying EVAPO-RUST™ on the rusted area?

No, EVAPO-RUST™ only works in liquid form, since the water in the solution will evaporate when sprayed. However, it can be sprayed on unrusted steel as a rust preventative.

### How can I use EVAPO-RUST™ on a surface too large to soak?

Place a sponge soaked in EVAPO RUST™ over the rusted area. Cover the sponge with plastic wrap and tape the wrap down to prevent moisture from escaping. Remove in 24 hours and rinse with water.

### How long does EVAPO-RUST™ last?

One gallon of EVAPO-RUST™ will remove moderate rust from 300 pounds of steel. If any of the bath evaporates, simply replace with fresh tap water.

### How do I know when the bath is spent?

The bath will turn completely black and will not remove rust.

### How do I dispose of the spent solution?

Pure EVAPO-RUST™ can be safely poured into the city sewer. When the solution is spent, only the iron content will dictate the disposal method.

### What sizes is EVAPO-RUST™ available in?

It comes in quarts, gallons, 5-gallon pails, 55 gallon drums and 275 gallon totes.

# Universal Spill Absorbents Granules

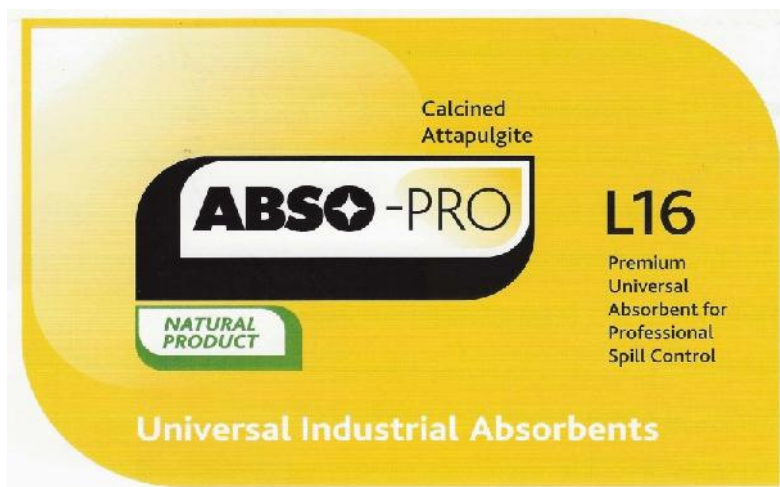

## ABSO-PRO® L16

Calced Attapulgit LVM 16/60

### General description

A premium, all-purpose absorbent with hard, non-slaking granules, made from calcined attapulgit clay.

### Functional use

Dust-free, slip-resistant and non-flammable qualities suit intensive applications for routine or emergency use in the workplace.

### General characteristics

- Inert Mineral Absorbent
- Non-Combustible, Non-Flammable
- Lightweight
- Free Flowing
- High Surface Area
- High Oil Absorption
- High Water Absorption
- Hard, Moisture Resistant Granules
- Non-Swelling
- Low Dust Content

### Technical data

Material Type: Calcined Attapulgit

Appearance: Beige Granules

	TYPICAL	SPECIFICATION
Moisture Content (105° C)*, %:	2	4 max
Water Absorption (Westinghouse Method), %:	135	
Oil Absorption (Westinghouse Method), %:	100	
Granulometry: 16/60 (0.250 – 1.18 mm)		
Sieve Analysis:		
Percent Plus 16 Mesh (+ 1.18 mm):	3	8 max
Percent Minus 60 Mesh (- 0.250 mm):	3	8 max
Apparent Bulk Density, g/cm <sup>3</sup> :	0.57	
pH (5% Suspension):	8	



## Spill Trays with Grids

Spill Trays are ideal for catching minor leaks and spills in the workplace and are great for storing smaller drums and containers. Compact and lightweight they can fit into small areas are robust, easy to clean, compatible with most liquids and are DIBt approved

The Spill Tray range can be used and purchased with or without grids.

### FEATURES

- Robust and durable
- Low profiles for limited height applications
- Broadband chemical compatibility

With sump capacities up to 104 litres available in a range of sizes our spill tray range provides a practical, easy to use and safe solution to small liquid container storage.

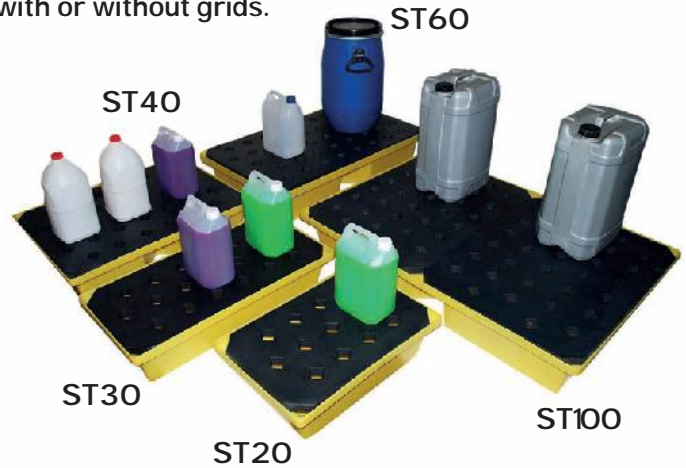

## Drip Trays

Compact and easy to clean our Drip Trays provide an excellent liquid dispensing work area, suitable for use with most oils and chemicals.



Code	Product	Colour	Sump	Weight	Size
ST20	Tray with Grid	●●●	22 Litres	3.5kg	60 x 40 x 17cm
ST30	Tray with Grid	●●●	31 Litres	4.5kg	81 x 41 x 17cm
ST40	Tray with Grid	●●●	43 Litres	7.5kg	80 x 61 x 17cm
ST60	Tray with Grid	●●●	63 Litres	10kg	100 x 61 x 20cm
ST70	Tray with Grid	●●●	70 Litres	9.5kg	80 x 61 x 32cm
ST100	Tray with Grid	●●●	104 Litres	15kg	120 x 80 x 19cm
TT9	Drip Trip	●	9 Litres	1.2kg	79 x 40 x 5cm
TT28	Drip Trip	●	28 Litres	1.3kg	65 x 49 x 12cm
TT64	Drip Trip	●	64 Litres	2.6kg	80 x 80 x 12cm
TT65	Drip Trip	●	65 Litres	2kg	100 x 55 x 15cm
TT100	Drip Trip	●	100 Litres	4kg	100 x 100 x 12cm

## Drum Workfloors

Our spill flooring range is the flexible decking solution for creating liquid handling workstations and storage areas to fit your working environment.

Great as separate units or combine to create a multiple workstation with a shared sump area. Ramp BFR provides easy access when using a drum trolley.



BF2

## Drum Trolley for Storage and Transportation

Trolleys with built-in sumps designed to allow you to safely transport drums of liquid around the workplace. Made from sturdy 100% polyethylene they offer broadband chemical compatibility and are lightweight.

Ensure your drums are fully protected even when being transported. Simple to use, one person operation. Dispense without the worry of spills.



Code	Product	Colour	Sump	UDL	Weight	Size
BFR	Ramp	●	n/a	1000kg	8kg	65 x 80 x 16cm
BF2	WorkFloor	●●	130 Litres	1000kg	20kg	126 x 86 x 15cm
BF4	WorkFloor	●●●	300 Litres	2000kg	38kg	166 x 126 x 15cm
BT230	Drum Trolley	●●	230 Litres	300kg	42kg	160 x 74 x 64cm



# Drum Spill Pallets

Available in 1, 2, 3, 4 and 8 drum versions our fully compliant 4-way access spill pallets\* accommodate forklift truck and pallet trucks which makes moving and positioning as easy as possible and all versions come with easy to remove plastic grids for easy access to the sump. \*BP2FW, BP4FW & BP8FW

## FEATURES

- Fork pockets for easy movement
- Regulation compliant
- Removable plastic grids
- Compatible with most liquids



4 way entry pallets



BP1



BP2



BP2R



BP2FW



BP3



BP4



Code	Product	Colour	Sump	UDL	Weight	Size
BP1	1 x 205ltr	●	225 Litres	300kg	22kg	90 x 70 x 53cm
BP2	2 x 205ltr	●	240 Litres	650kg	23kg	122 x 82 x 33cm
BP2R	2 x 205ltr	● ♻️	240 Litres	650kg	23kg	122 x 82 x 33cm
BP2FW	2 x 205ltr	●	230 Litres	1200kg	27kg	122 x 82 x 45cm
BP3	3 x 205ltr	●	228 Litres	900kg	30kg	179 x 78 x 24cm
BP4	4 x 205ltr	●	410 Litres	1250kg	44kg	131 x 131 x 37cm

## Drum Spill Pallets



BP4L



BP4LR



BFR3

BFR3 is for use with BP4L



BP4FW



BFR4 is for use with BP4FW

BFR4



BP8FW

Code	Product	Colour	Sump	UDL	Weight	Size
BP4L	4 x 205ltr	●●	230 Litres	1250kg	29kg	128 x 128 x 28cm
BP4LR	4 x 205ltr	●●♻️	230 Litres	1250kg	29kg	128 x 128 x 28cm
BFR3	ramp for BP4L	●	n/a	1000kg	33kg	174 x 100 x 28cm
BP4FW	4 x 205ltr	●●	250 Litres	1500kg	40kg	122 x 122 x 39cm
BFR4	ramp for BP4FW	●	n/a	1000kg	36kg	174 x 100 x 39cm
BP8FW	8 x 205ltr	●●	1150 Litres	2500kg	91kg	234 x 123 x 61cm



## Hard Covered Drum Spill Pallets

Our hard covered spill pallets are manufactured from polyethylene which gives them compatibility with a wide range of liquids and they are available in different configurations; 2 or 4 x 205ltr drum storage, small container storage or 1 x 205ltr horizontal drum on a cradle.

### FEATURES

- Delivered fully assembled
- Integral fork pockets
- Broadband chemical compatibility

**“Models BP2HC can be supplied to accept a padlock (not provided) while model BP4HC has a built-in lock.”**



BP2HC



BP4HC

## Polyethylene Storage Cabinets

Ideal for storing drums, small containers or for use as a spill kit station or PPE cupboard, our range of cabinets with built-in sumps are manufactured from polyethylene which gives them excellent chemical resistance and durability. Cabinets are available with adjustable/removable shelves, lockable doors and although the standard colour is yellow other colour options are available on a longer lead time.

### FEATURES

- Durable construction
- Broadband chemical compatibility
- Lockable doors



PSC1



PSC2



PSC3

Code	Product	Colour	Sump	UDL	Weight	Size
BP2HC	2 x 205ltr	●●	230 Litres	650kg	85kg	149 x 99 x 169cm
BP4HC	4 x 205ltr	●●●●	410 Litres	1250kg	121kg	147 x 142 x 207cm
PSC1	Small cabinet	●●●	30 Litres	12kg	15kg	54 x 42 x 99cm
PSC2	Tall cabinet	●●●●	70 Litres	52kg	44kg	65 x 57 x 165cm
PSC3	205ltr cabinet	●●●●●	225 Litres	300kg	50kg	74 x 92 x 184cm

# SUPER HIGH PRESSURE LARGE CAPACITY

# KYOWA TESTER

## FEATURES



- Achievement of high pressures 5, 30, 50, 100MPa by simple mechanism and simple operation
- Easy-to-carry handy type
- Lightweight and rust-free plastic tank, with dust-proof cover
- With direct-coupled type ball tap available for city water supply, ... easy to feed water
- Pressure gauge with 100  $\phi$  large vibration absorber
- The closing valve is of special construction of Kyowa original design.
- T-50N is designed for large suction/discharge rate and light-weight, having the capacity several times the conventional model
- T-50N is simply connected with a 1.5m high pressure hose with one-touch coupler.

## SPECIFICATIONS

	Max pressure MPa	Plunger dia.	Stroke mm	Suction rate/stroke c.c.	Tank volume $\ell$	Discharge nozzle size	Weight kg	Size L×H×W	Accessories
T-50NDX	5	30	45	32.0	18	3/8	11.5	580 X 380 X 265	Hose ass'y with coupler 3/8×1m
T-300NDX	30	12	45	5.0	18	3/8	11.5	580 X 380 X 265	Hose ass'y 3/8×1m
T-500NDX	50	8	30	1.5	18	3/8	13.5	580 X 400X 265,	Hose ass'y 3/8×1m
T-1000NDX	100	8	30	1.5	18	3/8	13.5	580 X 400X 265,	Hose ass'y 3/8×1m

\*The above specification is subject to change without prior notice. Caution other similar products. Our N-Series is patented.

# KYOWA TEST PUMP HYDRAULIC PRESSURE TEST PUMP

Epoch-making Mechanism  
Featuring Rational &  
Functional Merits....Developed Under Kyowa's  
Power Test Pump Technology!!



## SPECIFICATIONS (50kg/cm<sup>2</sup> pressure gauge is available if desired.)

Item Model	Maximum Pressure	Plunger Diameter	Stroke	Rate of Water Suction Per Stroke	Capacity of Water Tank	Size of Discharge Port	Weight	Dimensions L×H×W	Accessories
T-50K-P	5Mpa (50kg/cm <sup>2</sup> )	22mm	35mm	13cc.	4.5 $\ell$ Plastic tank	1/4	3.3kg	320×300×200mm	Pressure gauge 1/4PT 1 Pressure hose 1 Union joint 1/2 1 Bushing 1/2×1/4 1
T-100K	10Mpa (100kg/cm <sup>2</sup> )	22mm	35mm	13cc.	5.2 $\ell$ Steel tank	1/4	7.0kg	370×300×210mm	Pressure gauge 1/4PT 1 Ultra high pressure hose 1/2 PF×1m 1 1/4 nipple 1

\*Specifications may be subject to change without notice. \*KYOWA's products are patented. Give careful attention to imitations.